

What Is **MSI**?

- Multiple Sensors
 - LIDAR
 - SONAR
 - Fisheye Video
 - H2S Gas & Temp - OPTIONAL
- **2D** LIDAR
- **3D** LIDAR
- Quantitative measurable data

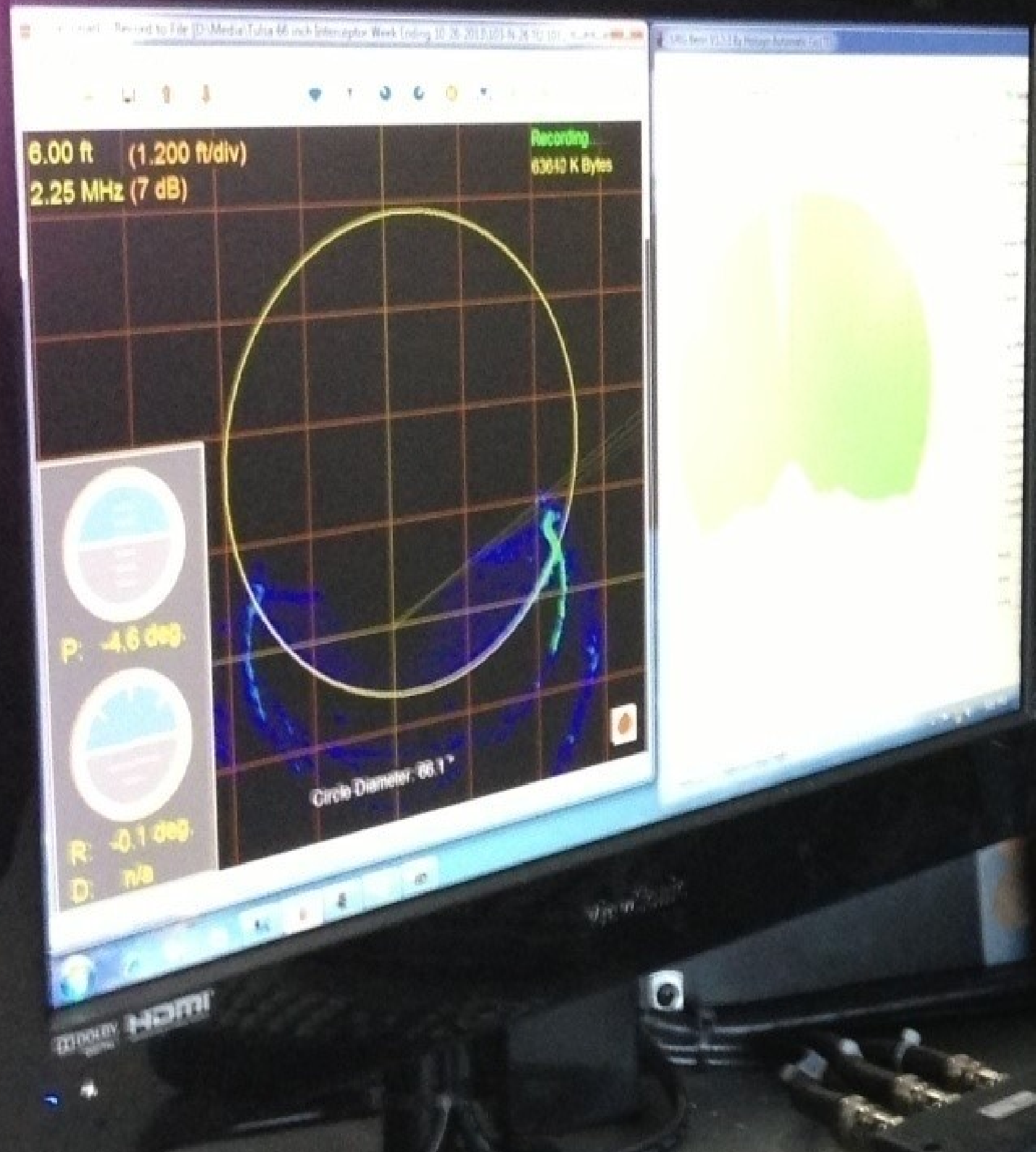

SolidFX MSI Equipment

- State-of-the-Art 2D LIDAR Inspection
- FLOAT for 36" and larger pipe
 - Up to 5400 LF
- SMM for 24" and larger pipe
 - Up to 3000 LF
- View and verify data quality in real time
- Code in back office for QA/QC
- Lens cleaning for I&I

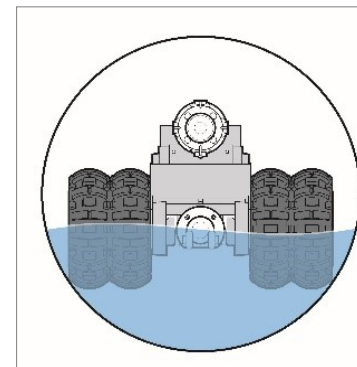
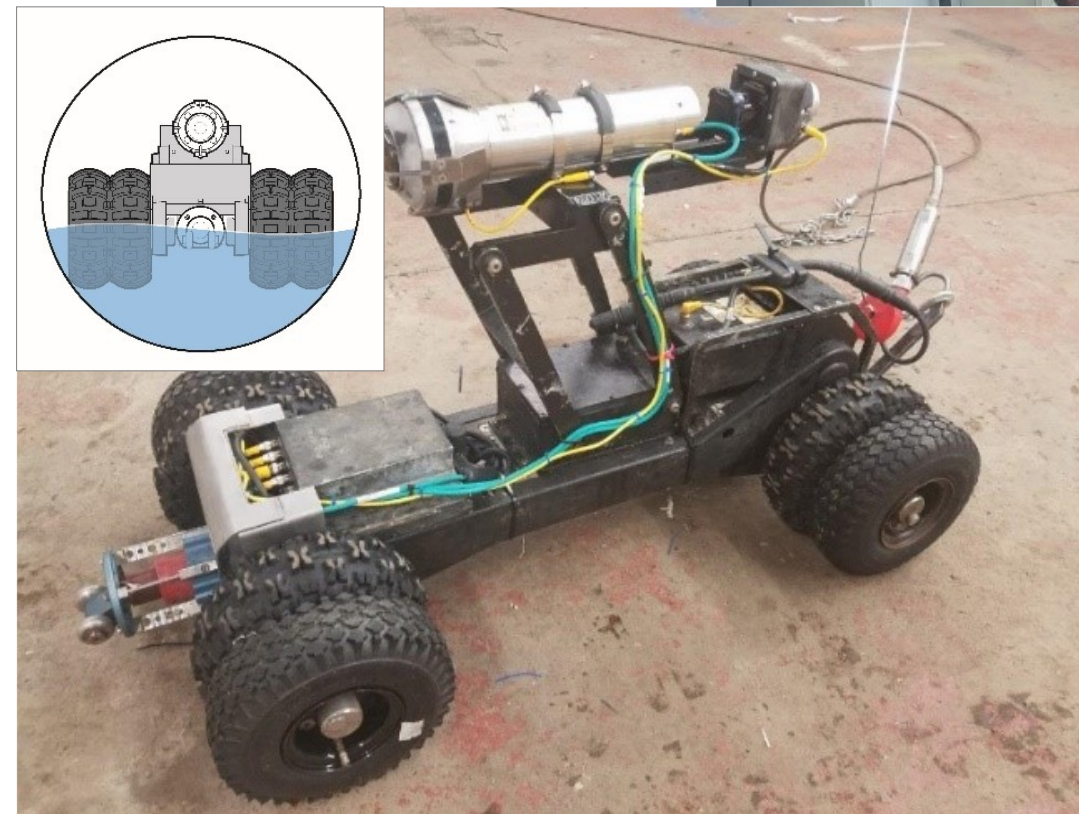
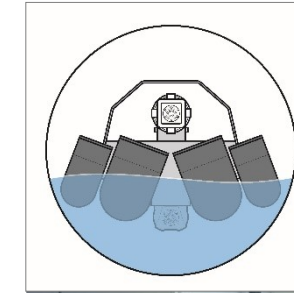

LIDAR view

DUC view

SONAR view

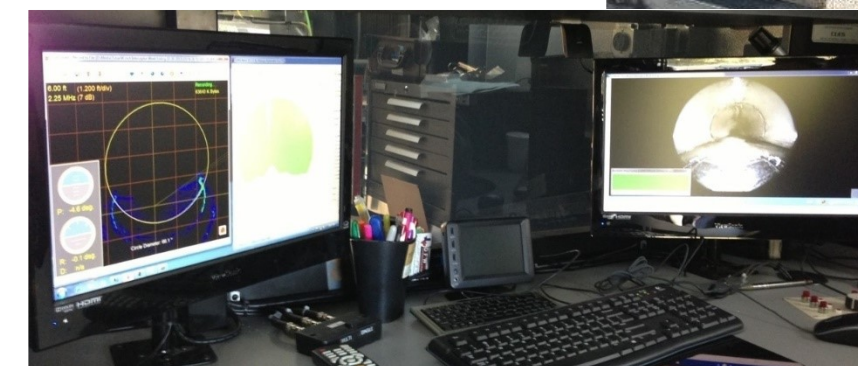

SFX-DUC Camera

Digital Universal Camera (DUC)

- Live video during inspection
- Digital pan-tilt-zoom
- Never miss a defect
- Integrated with GNet
- Code in truck or in office
- Flat images with measuring capabilities
- No moving parts

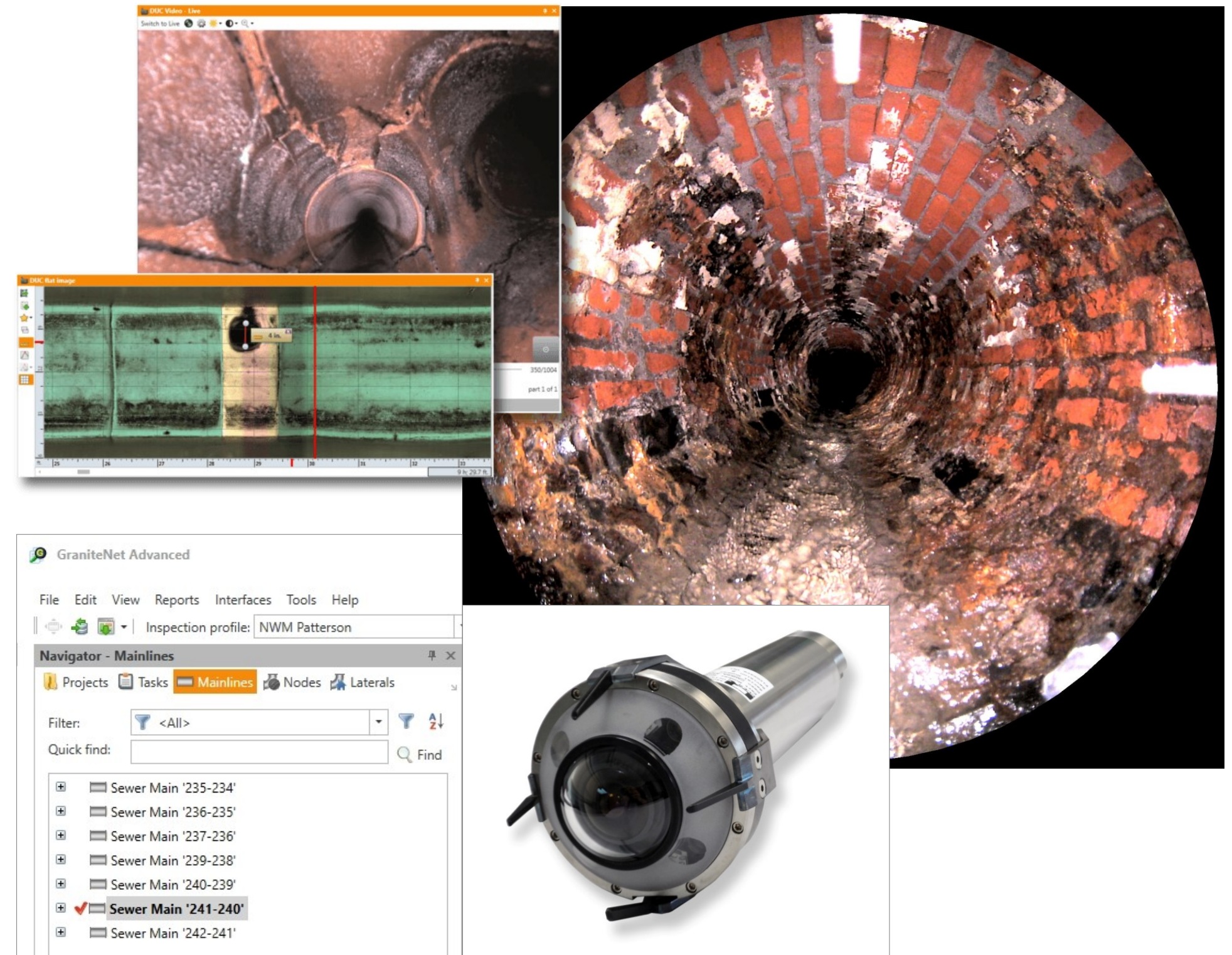

SFX-SONAR

Profiling SONAR

- Frequency = 2.25 MHz
- Beam = 1.4-deg conical
- RPM = 1 rev/sec
- Range = 6" - 180" (15 ft.)
- Pitch & Roll
- Debris level
- Water level
- Capacity Analysis
- On-screen measurements

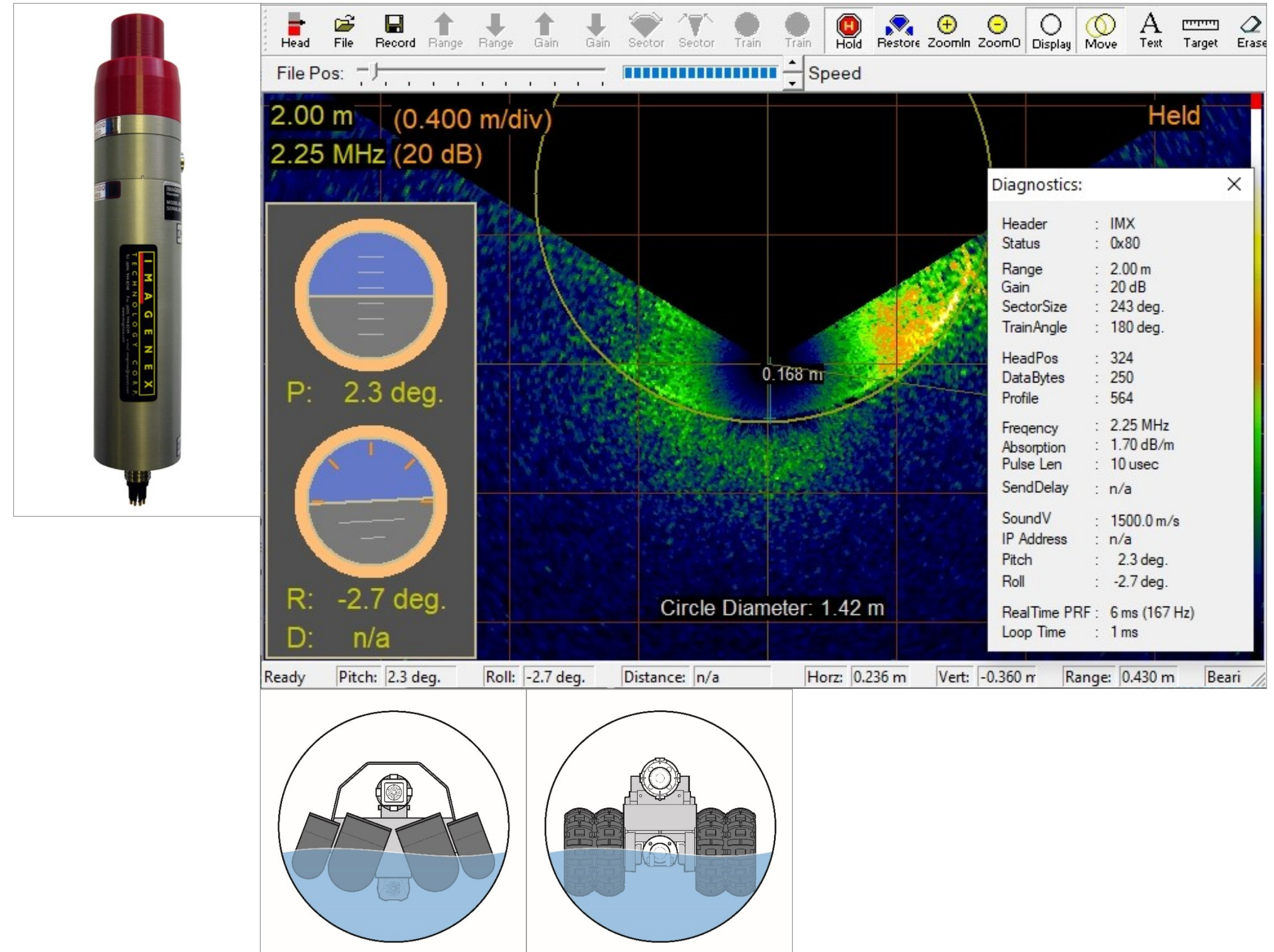

SFX-2D LIDAR

2D Scanning LIDAR

- 2D SCANNING LIDAR
- Live view
- On screen measurements
- 270 degree sweep @ 40 Hz
- 1080 points @ 1/4 deg/point
- Height & Width
- Ovality
- Corrosion & Buildup

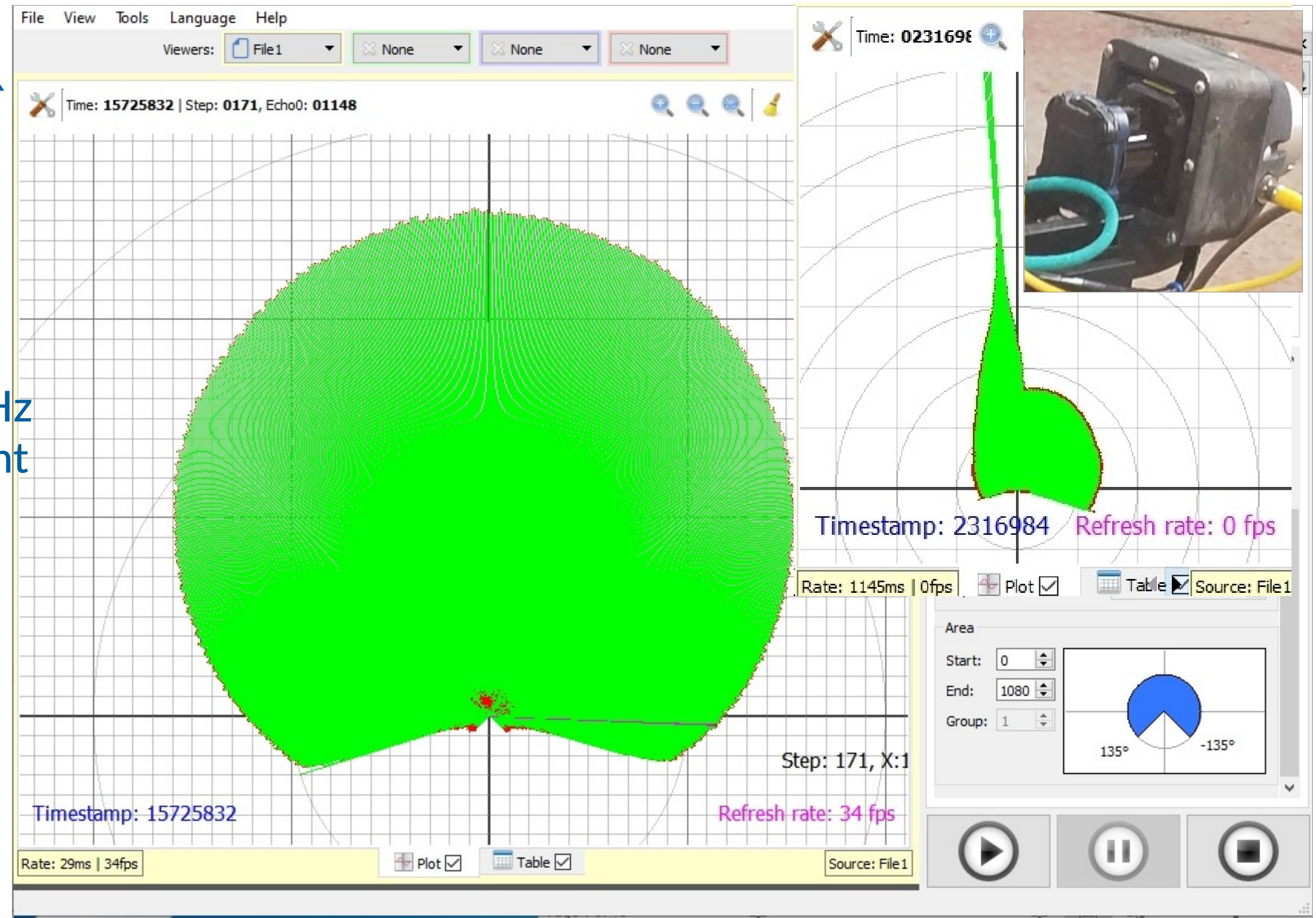

SFX-H2S Gas/Temp Sensor (optional)

H2S/TEMP-data logger

- H2S/TEMP – data logger
- Designed for sewers, manholes, and wet wells
- Wireless Bluetooth download of data
- Time synchronization with other MSI sensors
- Floats and self-righting

H2S Ranges	0-50, 0-200, 0-1000 and 0-2000ppm, Long Deployment (LD) or Short Deployment (SD) sensors available
Gas Accuracy at STP	+/- 2ppm at 20ppm gas (normal temperature and pressure)
Instrument Temp Range	-20C to 50C (-4F to 122F)
Relative Humidity Range	0-100% non-condensing
Ingress Protection	IP68
External Dimensions	Trilateral Diameter 58.3mm x 59.3mm Height 164mm (2.30" x 2.34" x 6.46")
Instrument Weight	300 grams (10.6oz)
Power Supply	3 x AA Alkaline Batteries (in adaptor) Or 1 x 3.6v D Lithium Battery
Logging Interval	1 second to 18 hours
Logging Capacity	3 million data points
Wireless Communication	Data download via <i>Bluetooth</i> [®]
Humidity Accuracy	+/- 5% RH @ 55% RH
Humidity Sensor Range	0-100%
Temperature Accuracy	+/- 0.3 @ 25C (77F)



SFX-Reporting Deliverables

- Granite Net database and DUC video file
- 4:1 VIDEO – Synchronized sensor view (MP4)
- Condition Assessment Report (PDF)
- Tabular Data (Summary Info) (CSV)

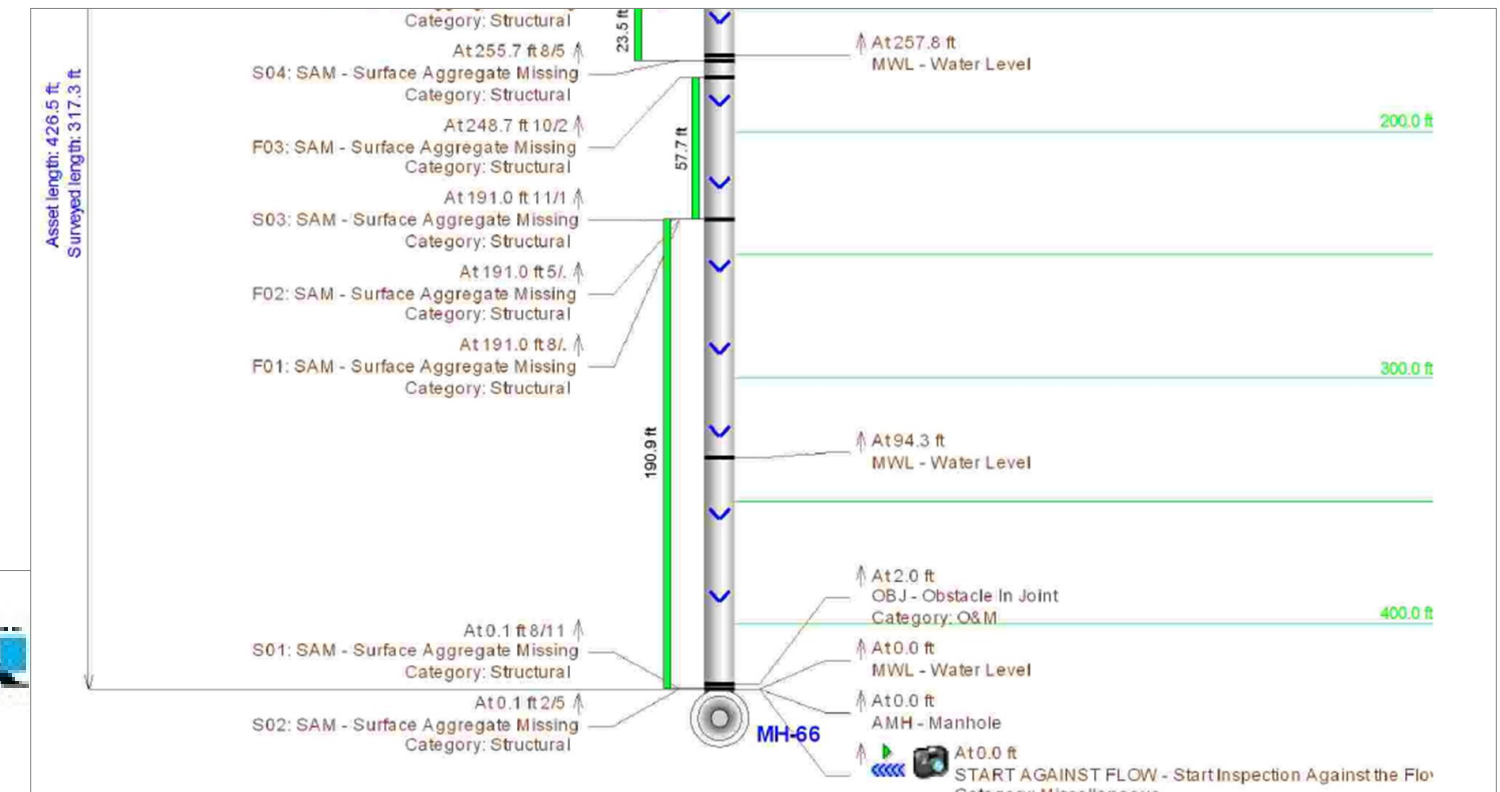

Anytown, USA
Upstream Manhole: 104433
Downstream Manhole: 231533

SolidFX

HD Video

Payout: 32.1
2017-11-30 09:02:33

Corrosion avg in: 0.27
Corrosion max in: 0.68

Water Height in: 17.0
Sediment Ht. in: 10.0

Rollout View

Cross Section View

Height - in

Payout - ft

corrosion max
corrosion avg

Pipe Diameter - 54"

Water Level - inches

Sediment height - inches

Payout - ft

Category: Miscellaneous				
0.013867596	2017_11_30_09_01_23198	86.66739156	2.147333956	5.123189999
0.014773519	2017_11_30_09_01_23224	86.74908718	2.168335546	5.33744858
0.015644599	2017_11_30_09_01_23249	88.60474504	2.21571583	5.488367359
0.016515679	2017_11_30_09_01_23274	90.71716059	2.181964199	5.488367359
0.01738676	2017_11_30_09_01_23299	89.73681304	2.147298754	5.33744858
0.01825784	2017_11_30_09_01_23324	78.48615785	2.103991424	4.948263487
0.042081633	2017_11_30_09_01_23349	89.620105	2.155747328	5.228985074
0.045142857	2017_11_30_09_01_23374	83.72634891	2.11037864	5.163934533
0.048326531	2017_11_30_09_01_23400	87.83447197	2.164946517	5.33744858
0.051020408	2017_11_30_09_01_23422	92.74788051	2.172976496	5.488367359
0.054326531	2017_11_30_09_01_23449	91.88424101	2.21507997	5.488367359
0.057510204	2017_11_30_09_01_23475	82.88605101	2.107107994	5.186547366
0.060571429	2017_11_30_09_01_23500	84.2632059	2.158815863	5.274763934
0.063632653	2017_11_30_09_01_23525	82.37253563	2.103689509	5.186235617
0.066693878	2017_11_30_09_01_23550	90.82219783	2.21888614	5.488367359
0.069755102	2017_11_30_09_01_23575	84.77672128	2.155203393	5.163934533
0.07295082	2017_11_30_09_01_23600	82.41921885	2.075084698	5.099194149
0.07602459	2017_11_30_09_01_23625	91.81421618	2.232759216	5.488367359
0.079221311	2017_11_30_09_01_23651	85.03347898	2.125692772	5.27402581

SFX-4:1 Viewer



PIPC
Upstream Manhole: GIS123
Downstream Manhole: GIS456





Payout: 29.7 Corrosion avg in: 0.27 Buildup avg in: 0.33
 2016-02-29 10:56:02 Corrosion max in: 1.27 Buildup max in: 2.53

HD Video

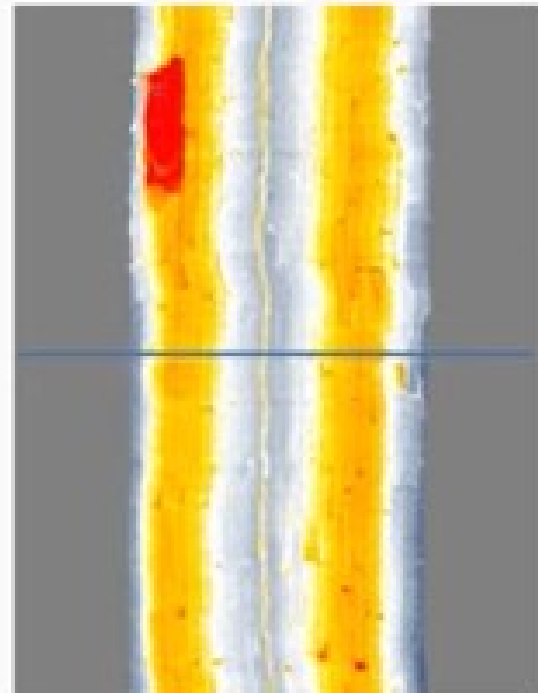

Rollout View

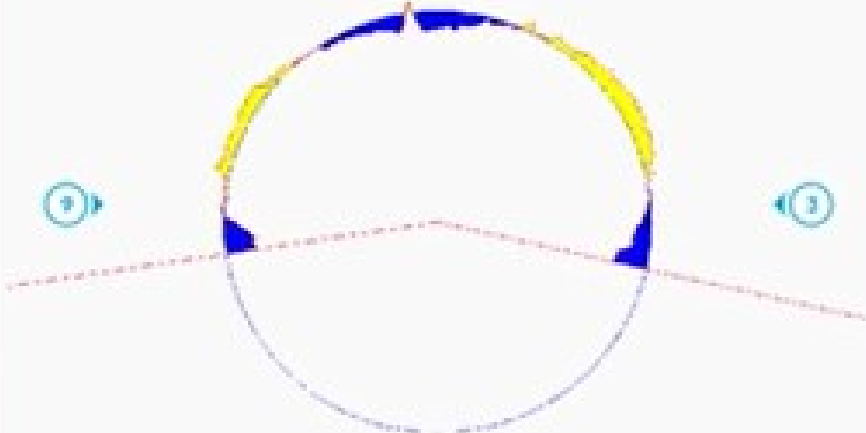

Cross Section View

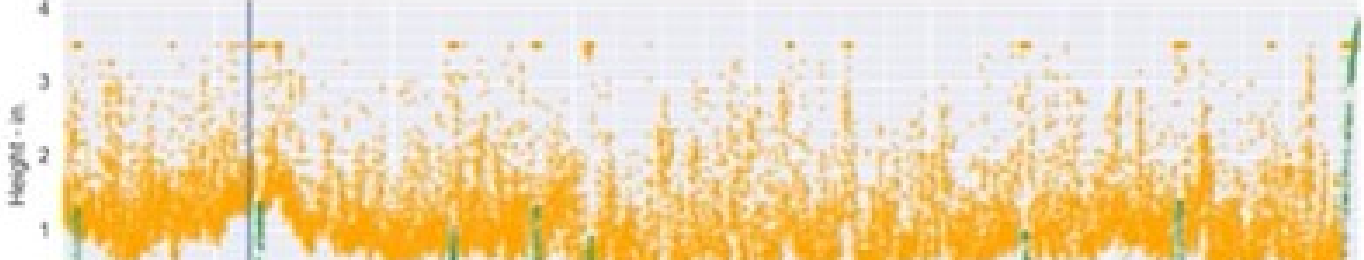
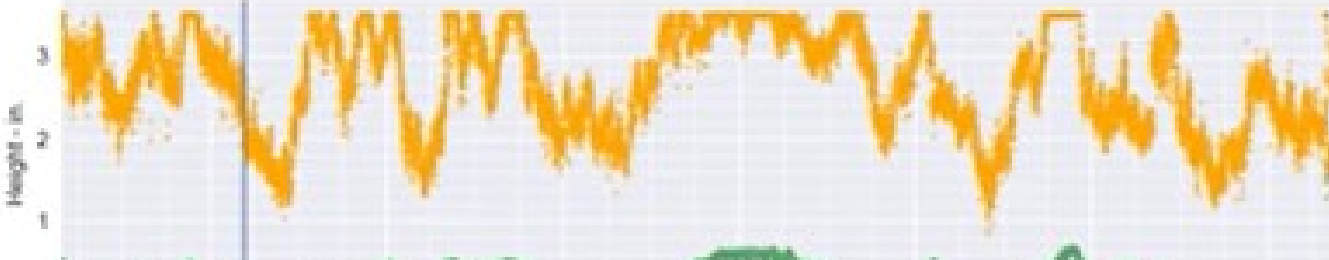



SFX-4:1 Viewer (cont.)



PIPC
 Upstream Manhole: GIS123
 Downstream Manhole: GIS456





Payout: 31.4
2016-02-29 10:56:08

Corrosion avg in: 1.33
Corrosion max in: 3.5

Buildup avg in: 0.27
Buildup max in: 1.98

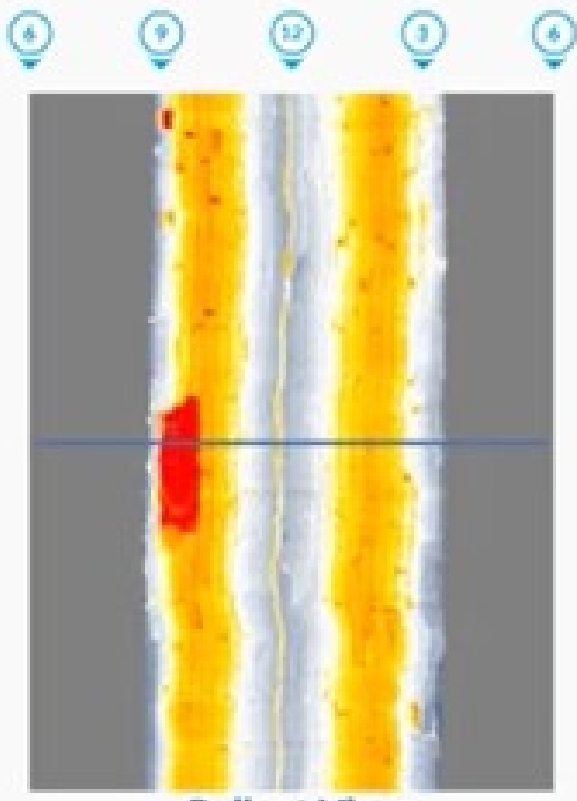

HD Video



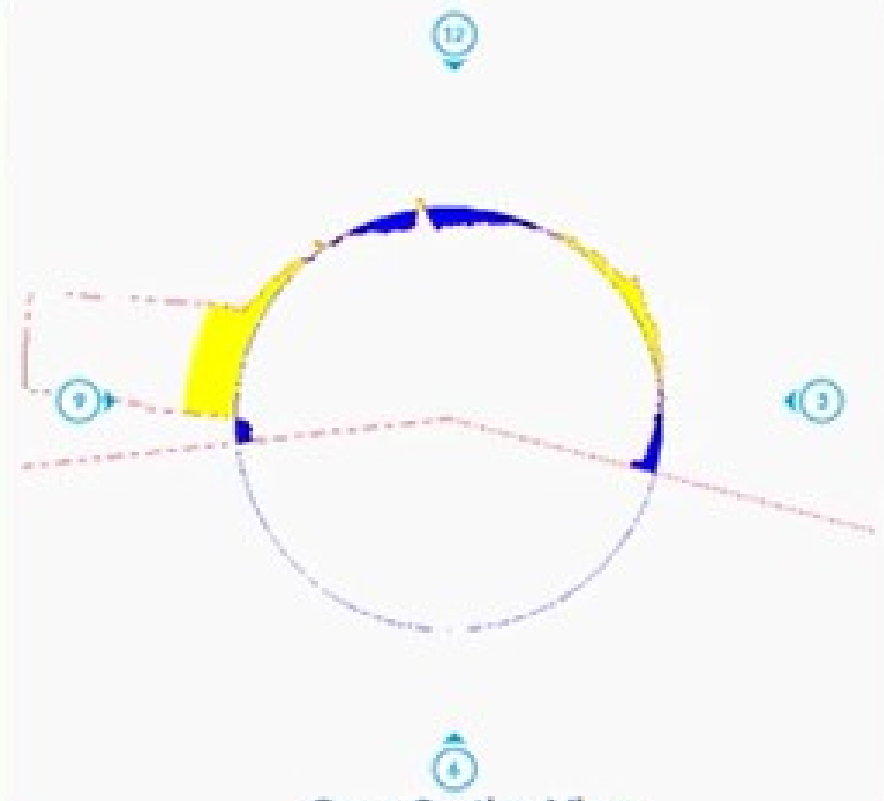

Rollout View

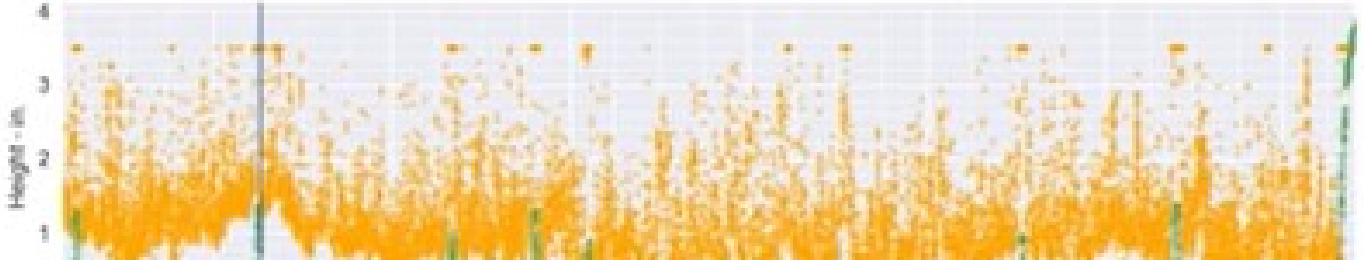

Cross Section View

SFX-Condition Assessment Report



Anytown, USA 104433
 Inspected November 30, 2017 231533

As-Built Dimensions

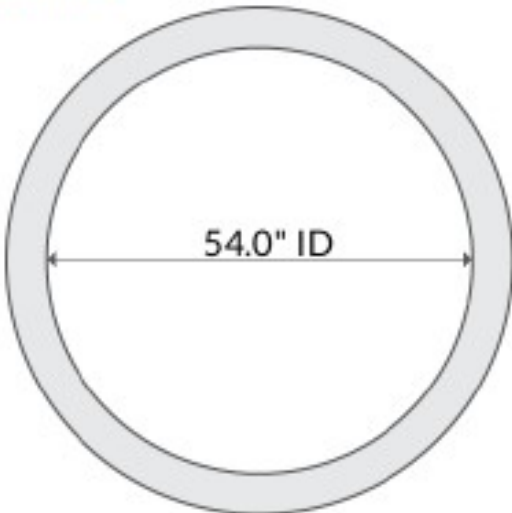

54.0" ID

Document Details

Report Prepared February 15, 2018
 Source Reference 52305

Inspection Information

Transport

Float

Sensor(s)

LIDAR
HD
SONAR

Inspection Details

Service Area:	AREA 3
Segment Reference:	167020
Upstream Manhole:	104433
Downstream Manhole:	231533
Direction:	Downstream
Distance:	406.0
Scan Date:	November 30, 2017
Operator Notes:	None
Processing Notes:	None

Table of Contents



Technology Comparison	3
Inspection Information	4
Sediment and Corrosion Summary Metrics	5
Sediment and Corrosion Graphs	6
Pipe Ovality Graphs	9
Summary Table	10
Distributed Cross-Sections	13



SFX-Condition Assessment Report *(cont.)*



The Standard of the Industry



Anytown, USA 104433

Inspected November 30, 2017 231533

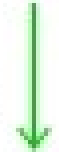

Sediment and Corrosion Summary Metrics

Sediment/Sonar Metrics

Sediment Volume (cubic yard):	10.1
As-is Capacity/As-built Capacity (%):	95.7
Average cross-sectional restriction (%):	4.3

Corrosion/Lidar Metrics

Corroded Volume (cubic in):	42126.5
Wall/As-built (%):	99.2
Average Wall Loss (%):	0.8



Table of Contents

Technology Comparison	3
Inspection Information	4
Sediment and Corrosion Summary Metrics	5
Sediment and Corrosion Graphs	6
Pipe Ovality Graphs	9
Summary Table	10
Distributed Cross-Sections	13

SFX-Condition Assessment Report *(cont.)*

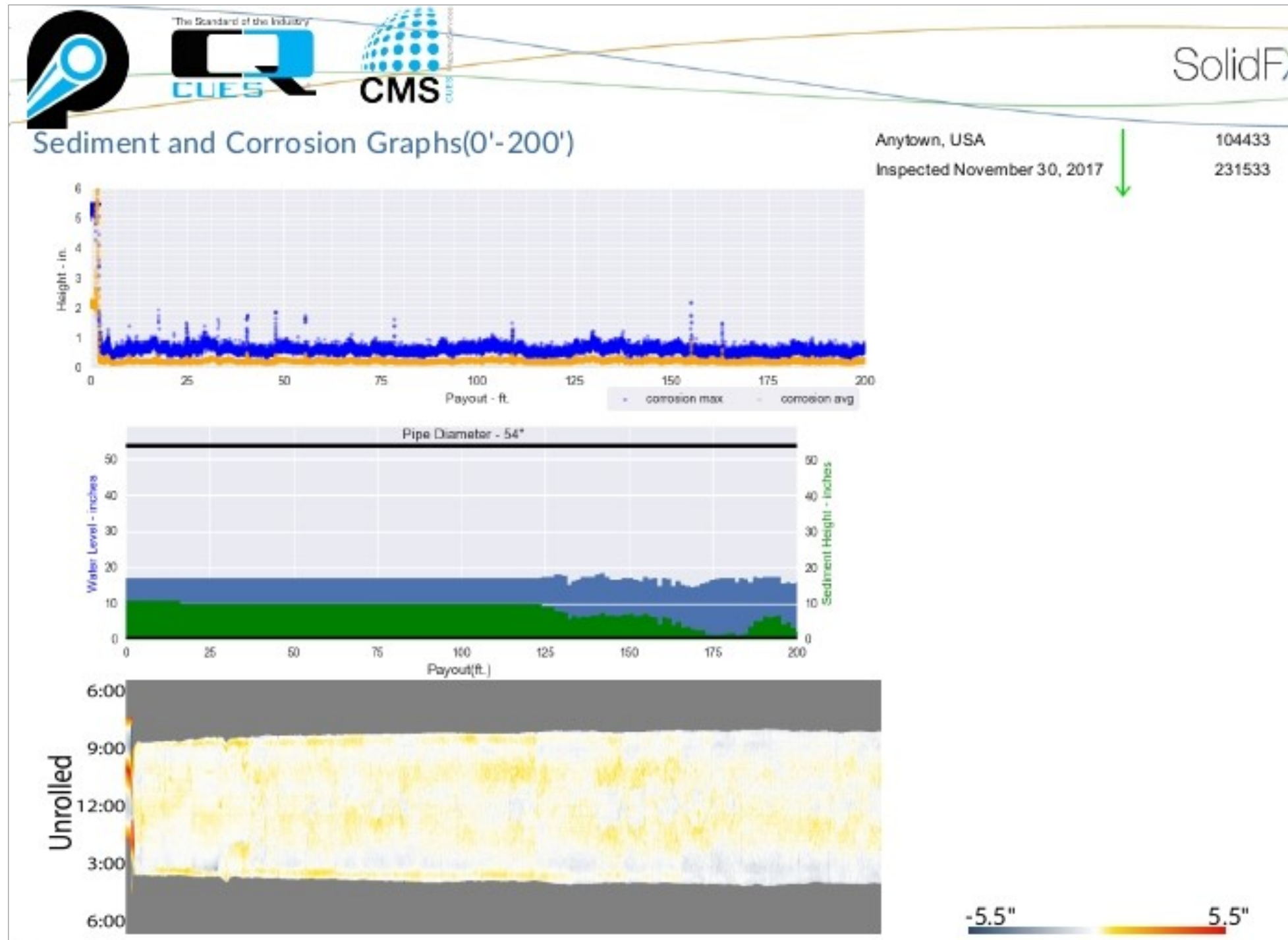

Table of Contents

Technology Comparison	3
Inspection Information	4
Sediment and Corrosion Summary Metrics	5
Sediment and Corrosion Graphs	6
Pipe Ovality Graphs	9
Summary Table	10
Distributed Cross-Sections	13



SFX-Condition Assessment Report *(cont.)*

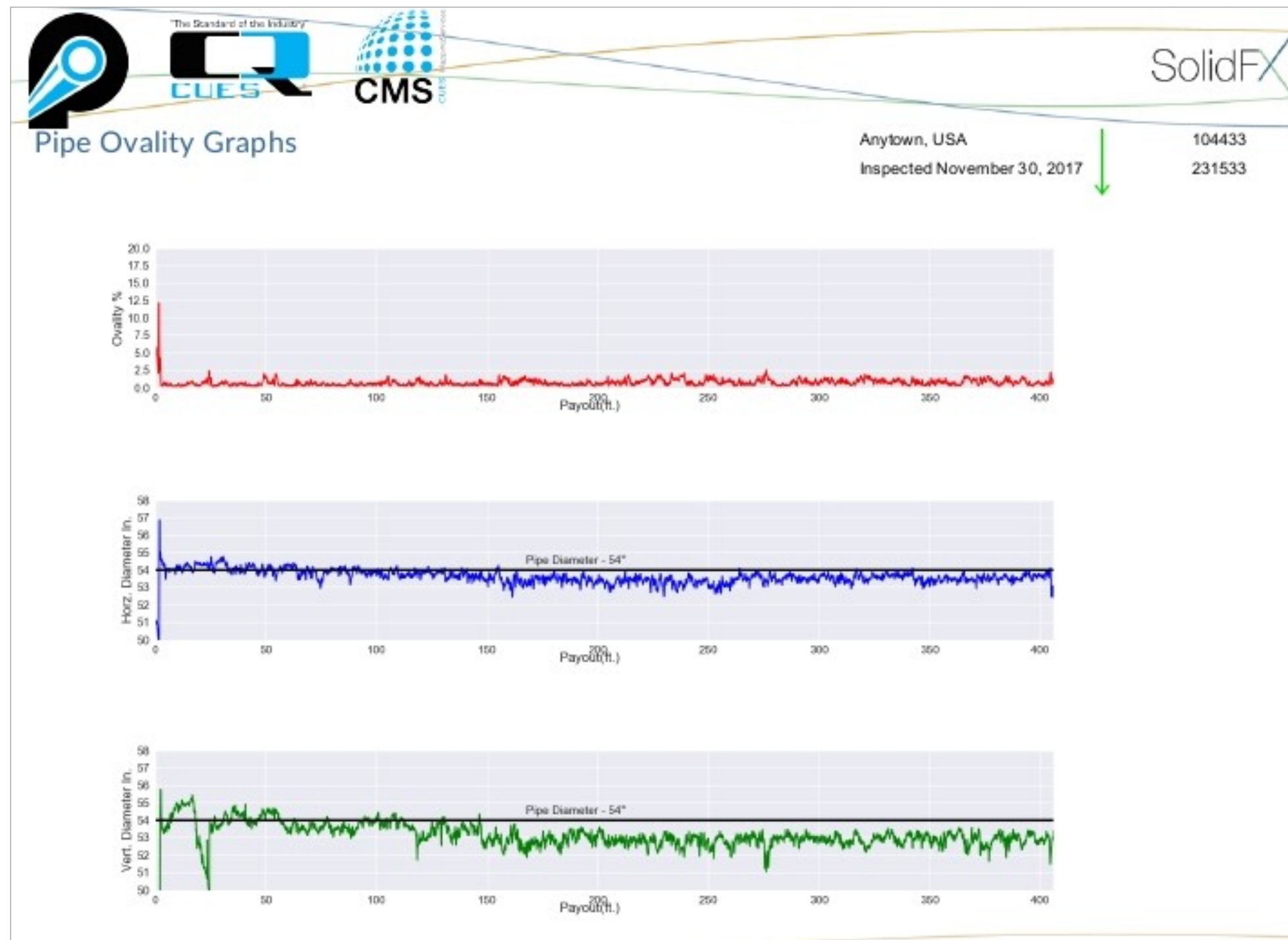

Table of Contents	
Technology Comparison	3
Inspection Information	4
Sediment and Corrosion Summary Metrics	5
Sediment and Corrosion Graphs	6
Pipe Ovality Graphs	9
Summary Table	10
Distributed Cross-Sections	13



$$\text{Ovality} = \frac{(\text{Horizontal Diameter} - \text{Vertical Diameter})}{(\text{Horizontal Diameter} + \text{Vertical Diameter})}$$

Horizontal Diameter is width at maximum.
Vertical Diameter is 2 * Vertical Radius.
Vertical Radius is vertical distance from center of Horizontal Diameter to peak of circle

SFX-Condition Assessment Report (cont.)

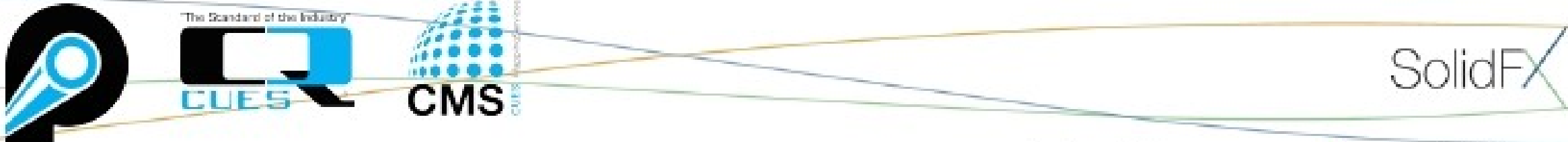

Anytown, USA
 Inspected November 30, 2017

104433
 231533

Summary Table

Payout	Type	Note	Av. Corr.	3s Corr.	Max Corr.	Av. Buildup	Max Buildup	Sed. Max Ht.	Sed. Restriction %
0.0'	Start	Start of inspection	2.1"	4.5"	5.5"	0.9"	1.5"	10.8"	9.8%
40.5'	Material Loss	Material Loss at Joint	0.4"	1.3"	1.8"	0.2"	0.7"	10.0"	9.4%
47.8'	Material Loss	Material Loss at Joint	0.4"	1.3"	1.6"	0.2"	0.5"	10.0"	9.4%
50.0'	Regular Interval		0.3"	0.4"	0.7"	0.3"	0.8"	10.0"	9.4%
55.5'	Material Loss	Material Loss at Joint	0.5"	1.5"	1.8"	0.2"	0.6"	10.0"	9.4%
100.0'	Regular Interval		0.2"	0.4"	0.6"	0.3"	0.8"	10.0"	9.4%
145.7'	Sediment	Sediment (0-205 ft.)	0.3"	0.4"	0.8"	0.3"	0.9"	6.7"	5.9%
150.0'	Regular Interval		0.3"	0.5"	0.7"	0.3"	0.9"	7.2"	7.3%
155.0'	Material Loss	Material Loss at Joint	0.7"	1.8"	2.2"	0.4"	1.4"	7.2"	7.5%
200.0'	Regular Interval		0.3"	0.5"	0.8"	0.3"	0.9"	2.2"	1.2%





Table of Contents

Technology Comparison	3
Inspection Information	4
Sediment and Corrosion Summary Metrics	5
Sediment and Corrosion Graphs	6
Pipe Ovality Graphs	9
Summary Table	10
Distributed Cross-Sections	13

SFX-Condition Assessment Report (cont.)

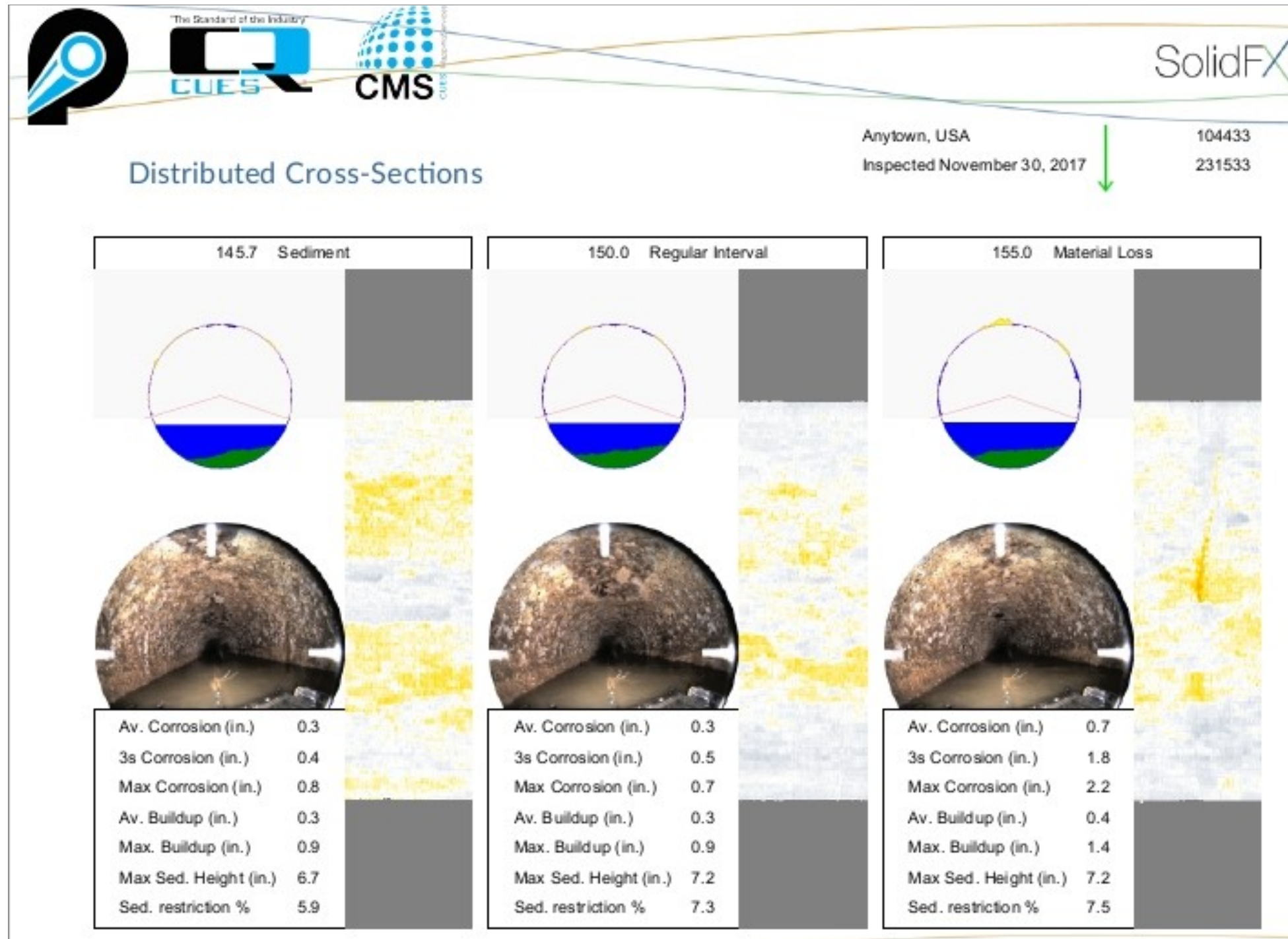
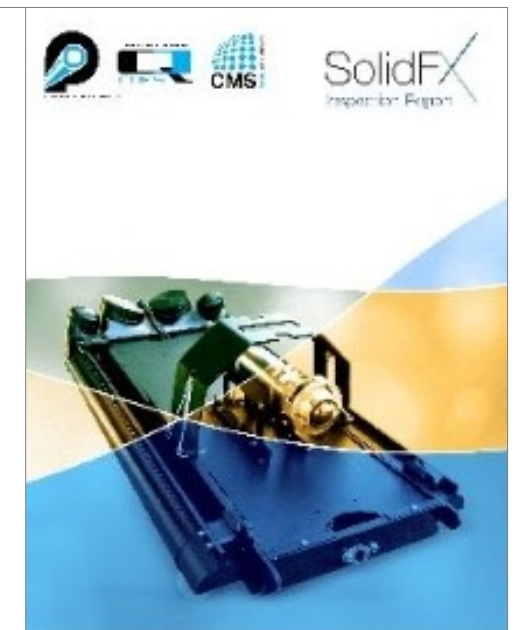

Table of Contents

Technology Comparison	3
Inspection Information	4
Sediment and Corrosion Summary Metrics	5
Sediment and Corrosion Graphs	6
Pipe Ovality Graphs	9
Summary Table	10
Distributed Cross-Sections	13



SFX-3D
Multi-Sensor Inspection



SFX-3D

Condition Assessment
 Rehab Planning
 Geo-Location

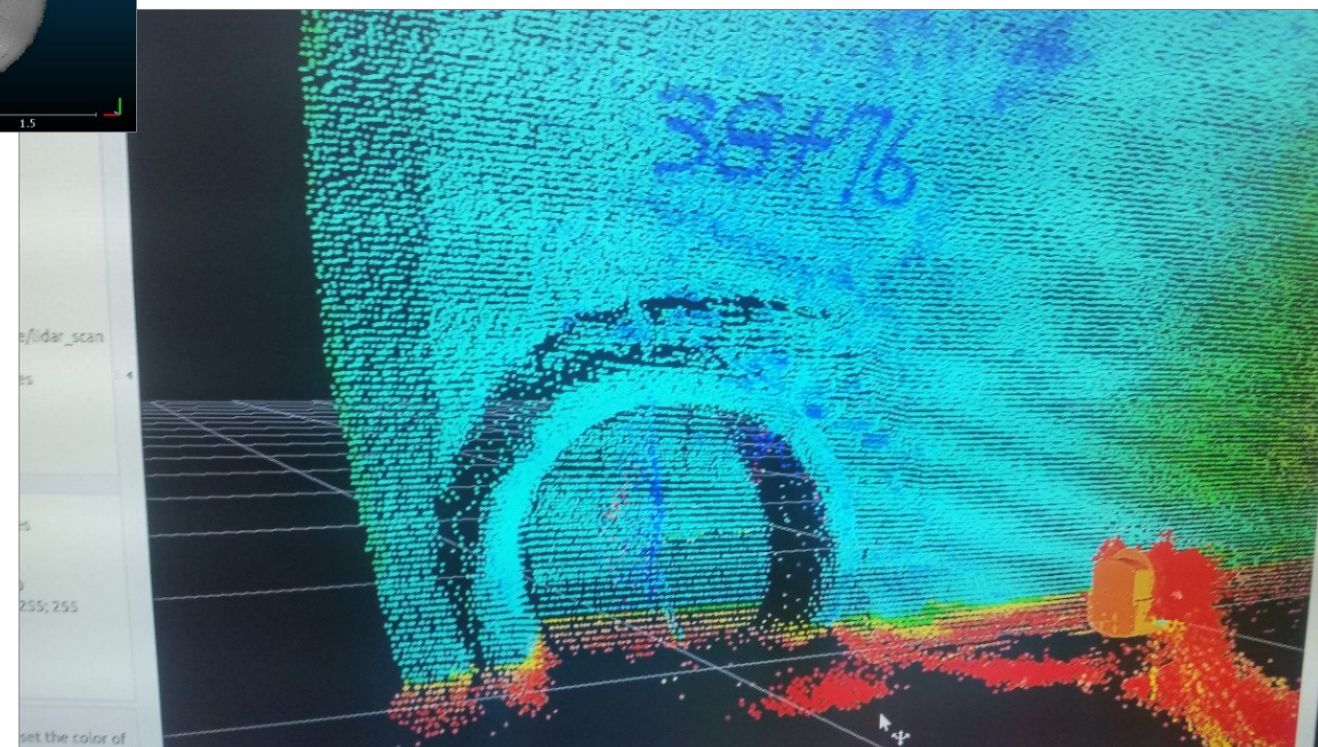
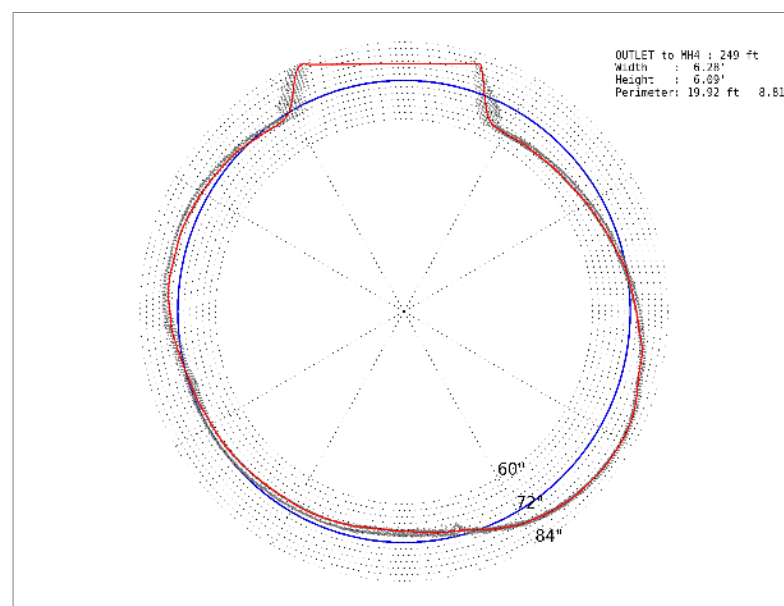
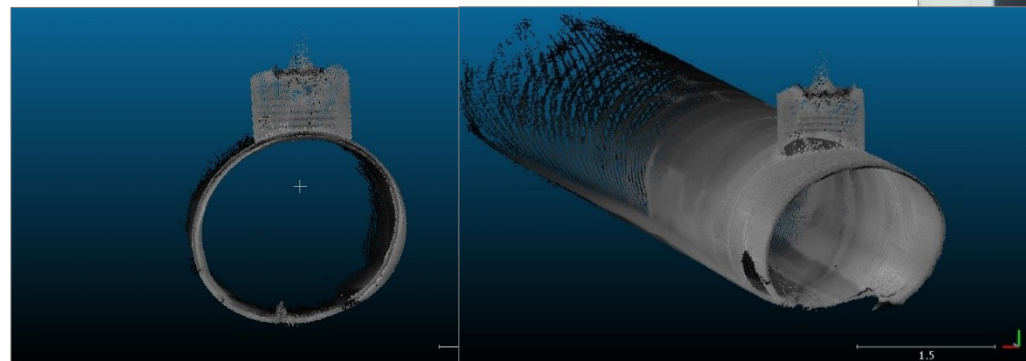
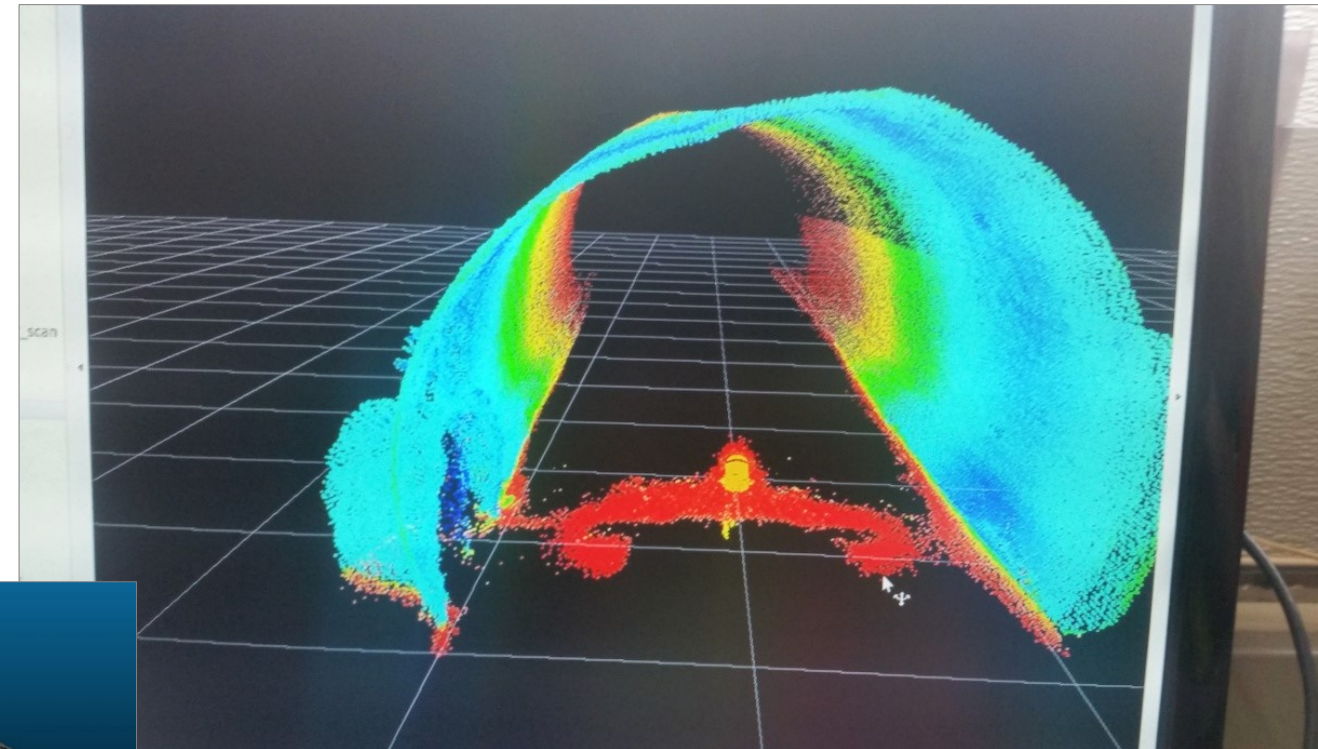

3D LiDAR

THE CUES SOLIDFX 3D MULTI-SENSOR PLATFORM

Used for condition assessment, rehabilitation planning, and geo-location mapping.

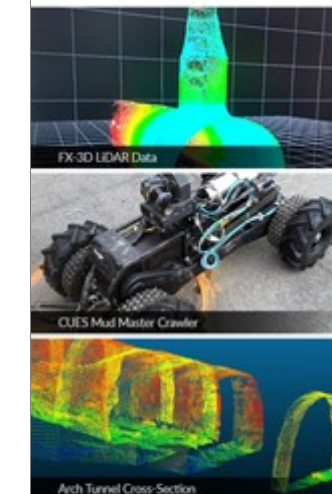

- Deployed from a stable skid or tractor
- Never miss a defect with the DUC camera
- Suitable for pipelines ranging from 36" to 240"
- The digital SONAR and DUC are complimented by 3D LiDAR
- LiDAR accurately measures cross sections & bends in the pipe
- Use LiDAR data and detailed scans to determine pipe centerline
- Collect high-density point clouds to accurately determine pipe size

Dual LIDAR Technology

Combine Data From Two Sensors

One SCAN Covers 40-70 Feet

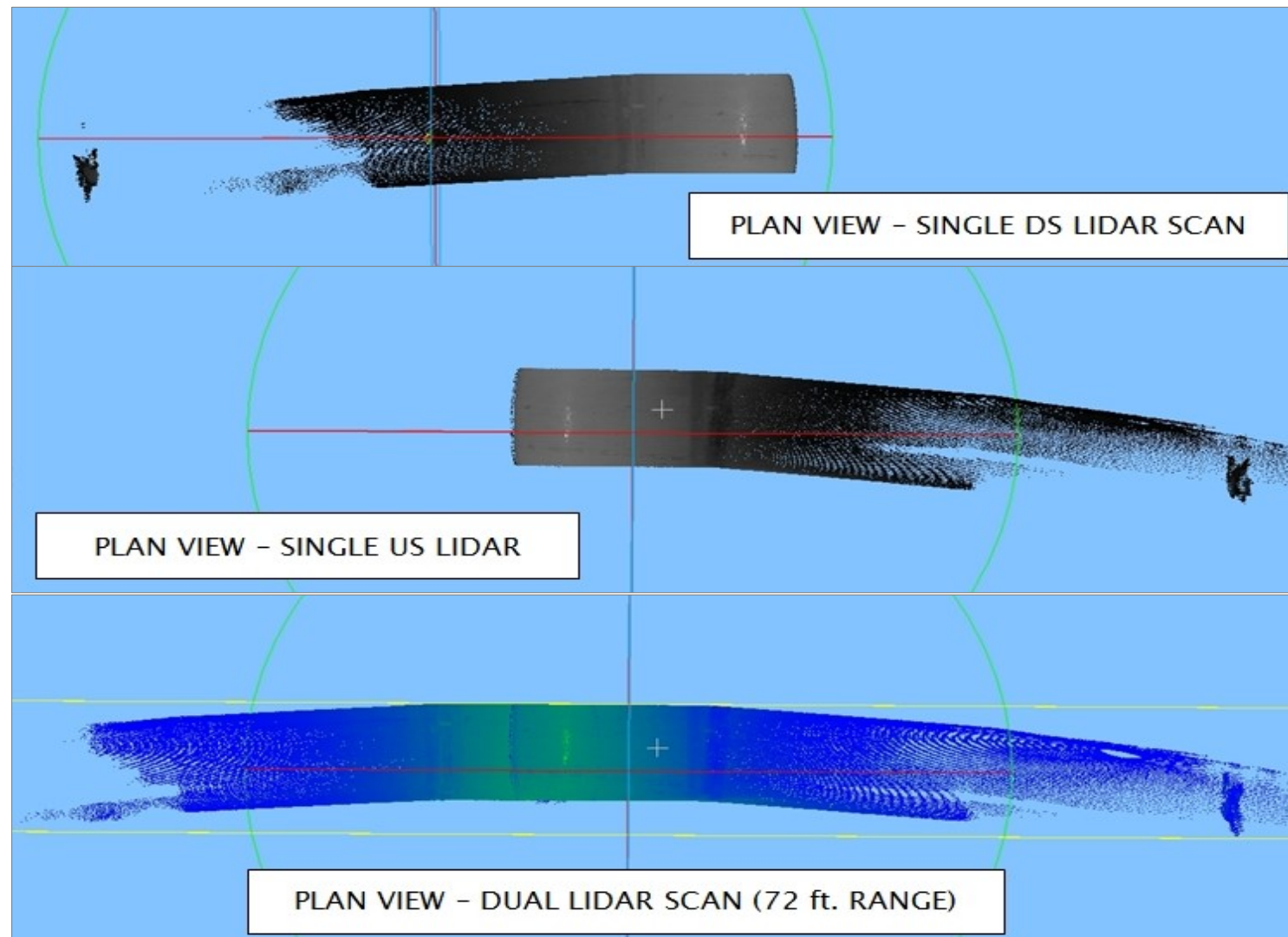

DUAL LIDAR Technology

Longer Point Cloud
More Accurate
Measurements

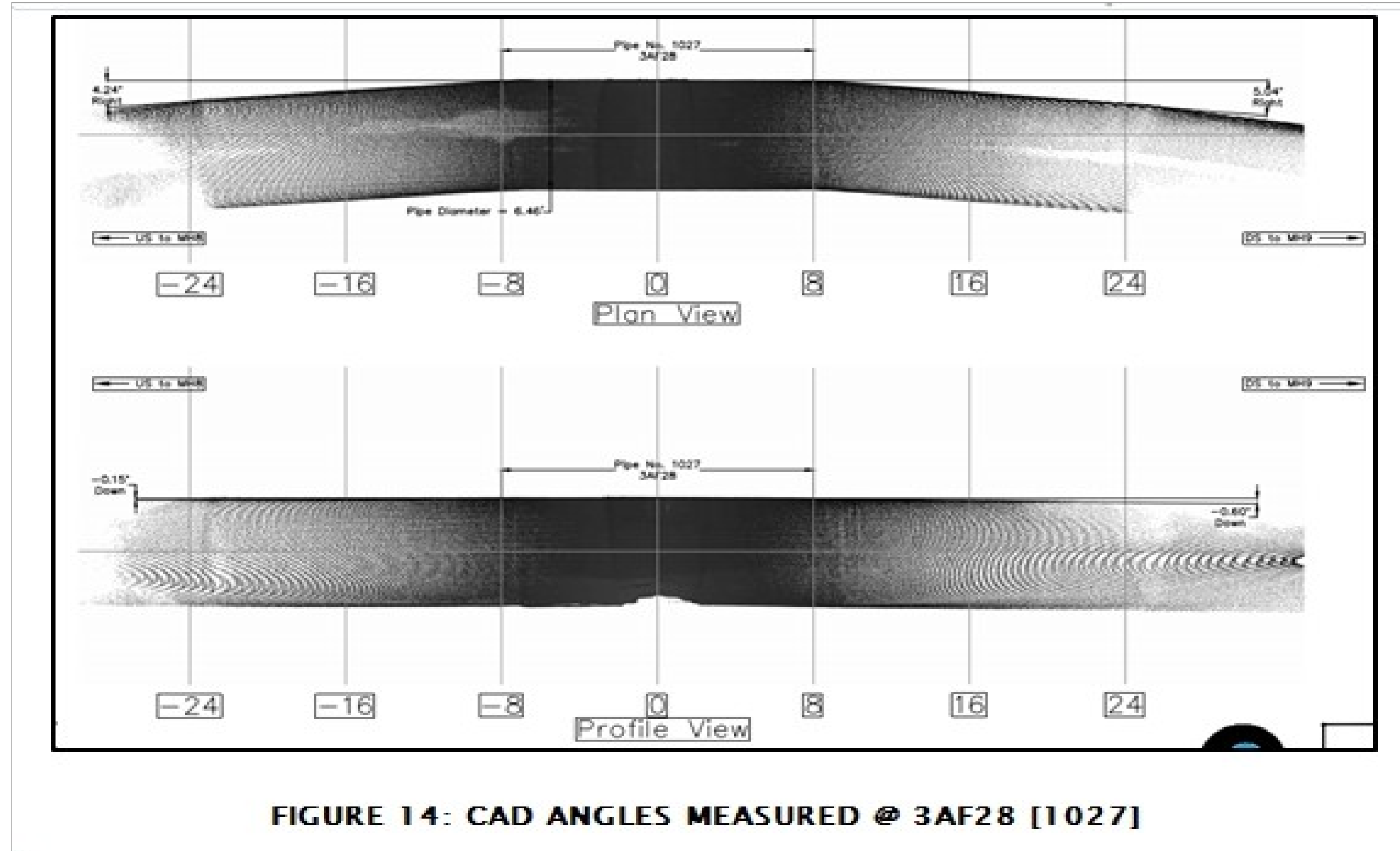

Detroit, MI – B39 OUTFALL

Size and Bend Analysis
For Slip-lining 13' Pipe

What are the angles of the bends?
What stick lengths and angle cuts are needed?
What is my lay plan?

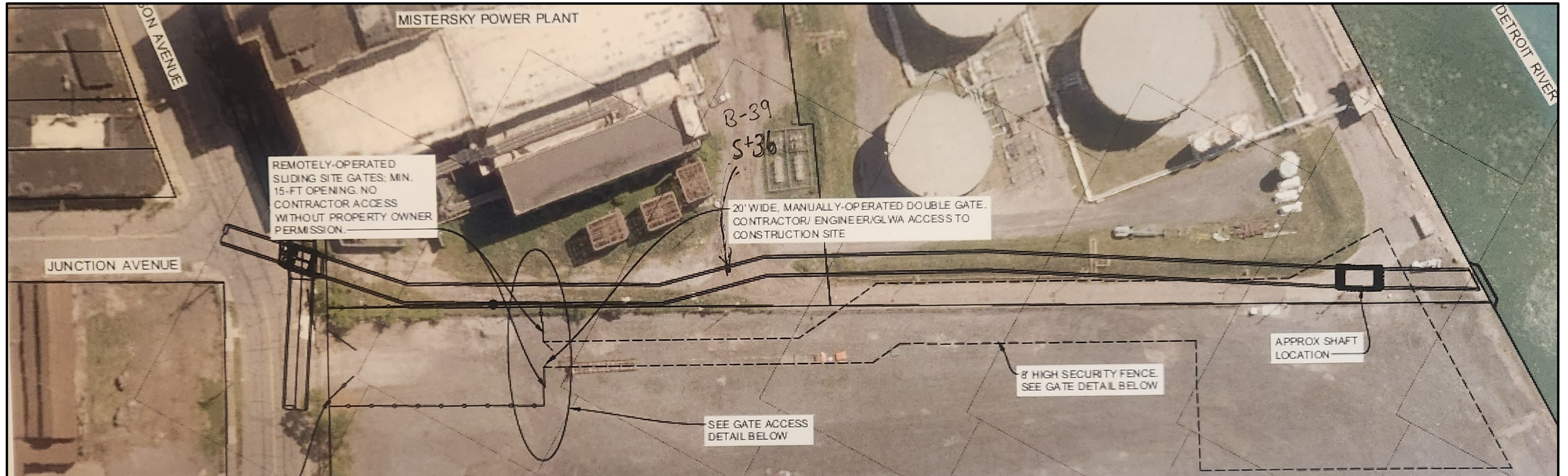

Detroit, MI – B39 OUTFALL

Field Work APRIL 2023
1 DAY to Collect Data

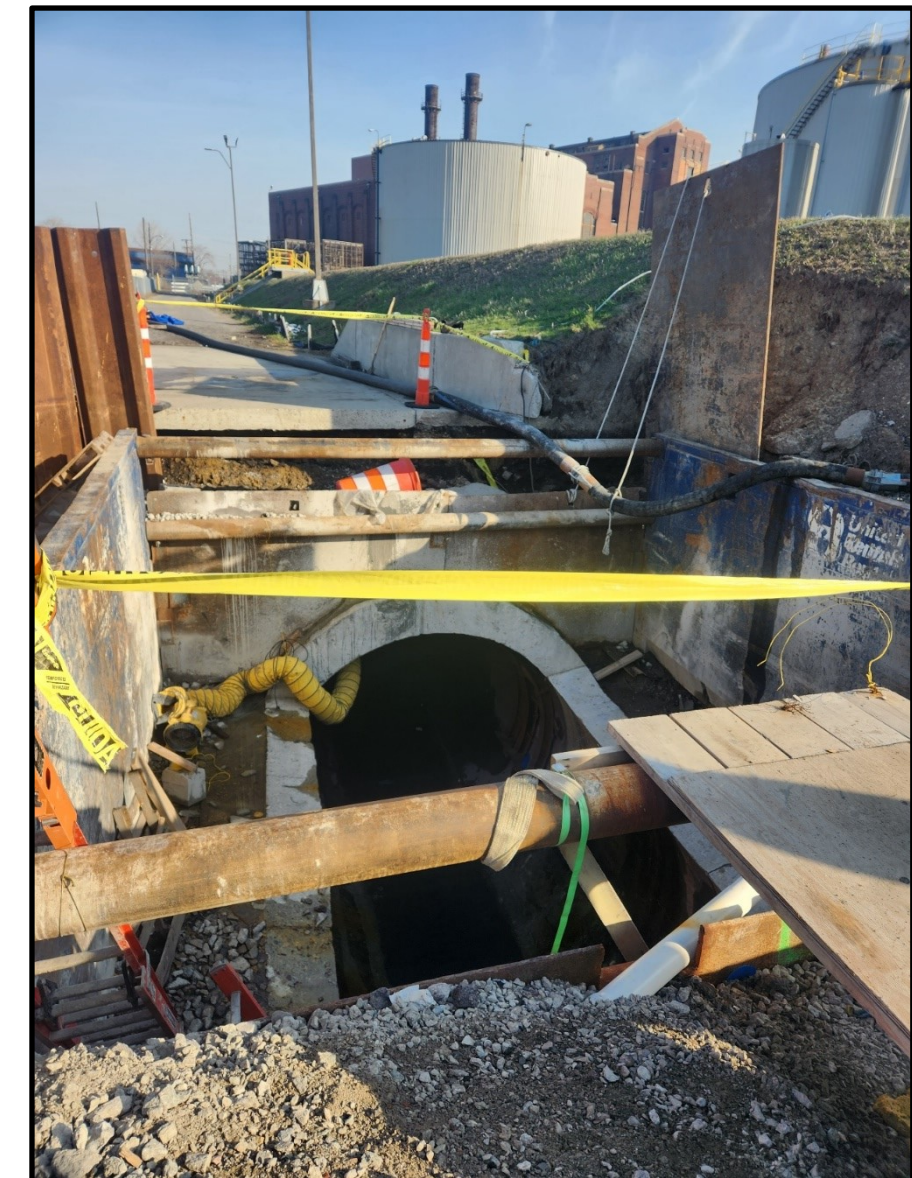
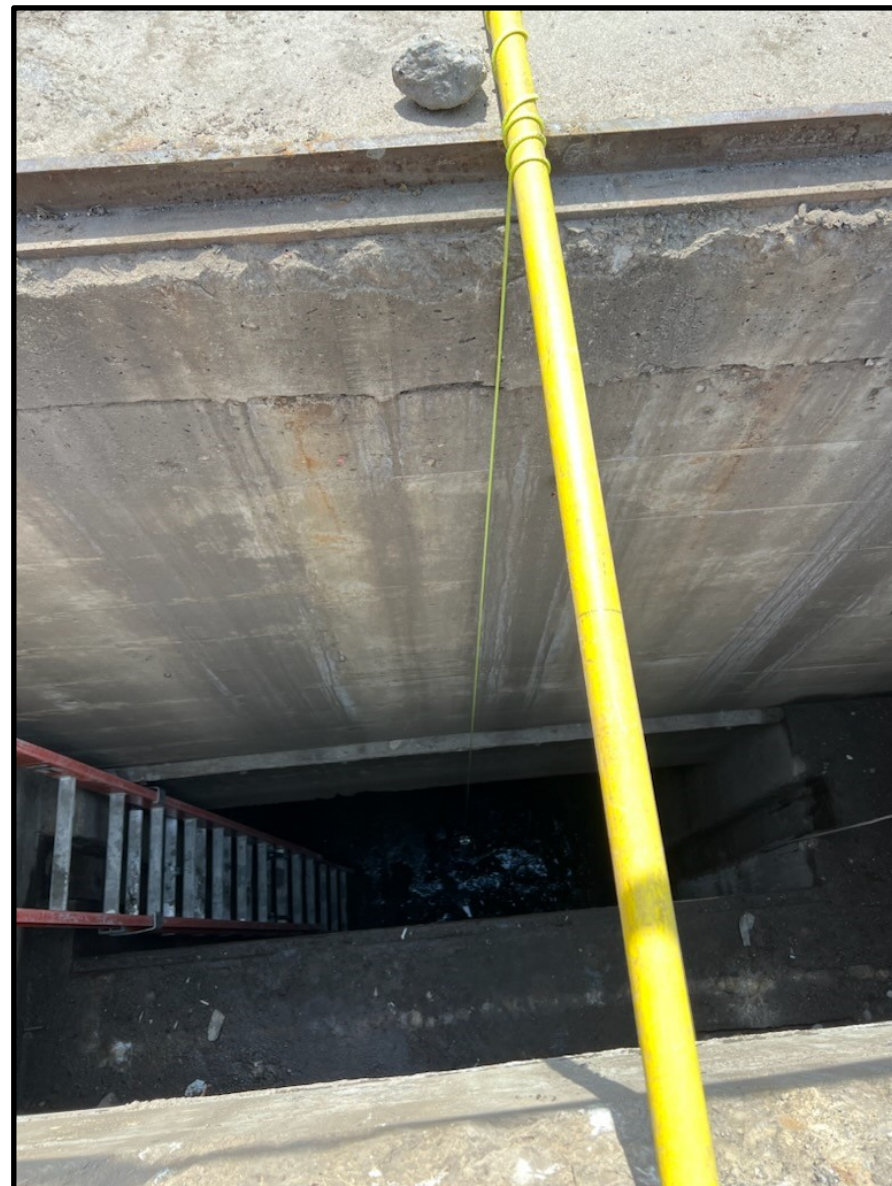

Detroit, MI – B39 OUTFALL

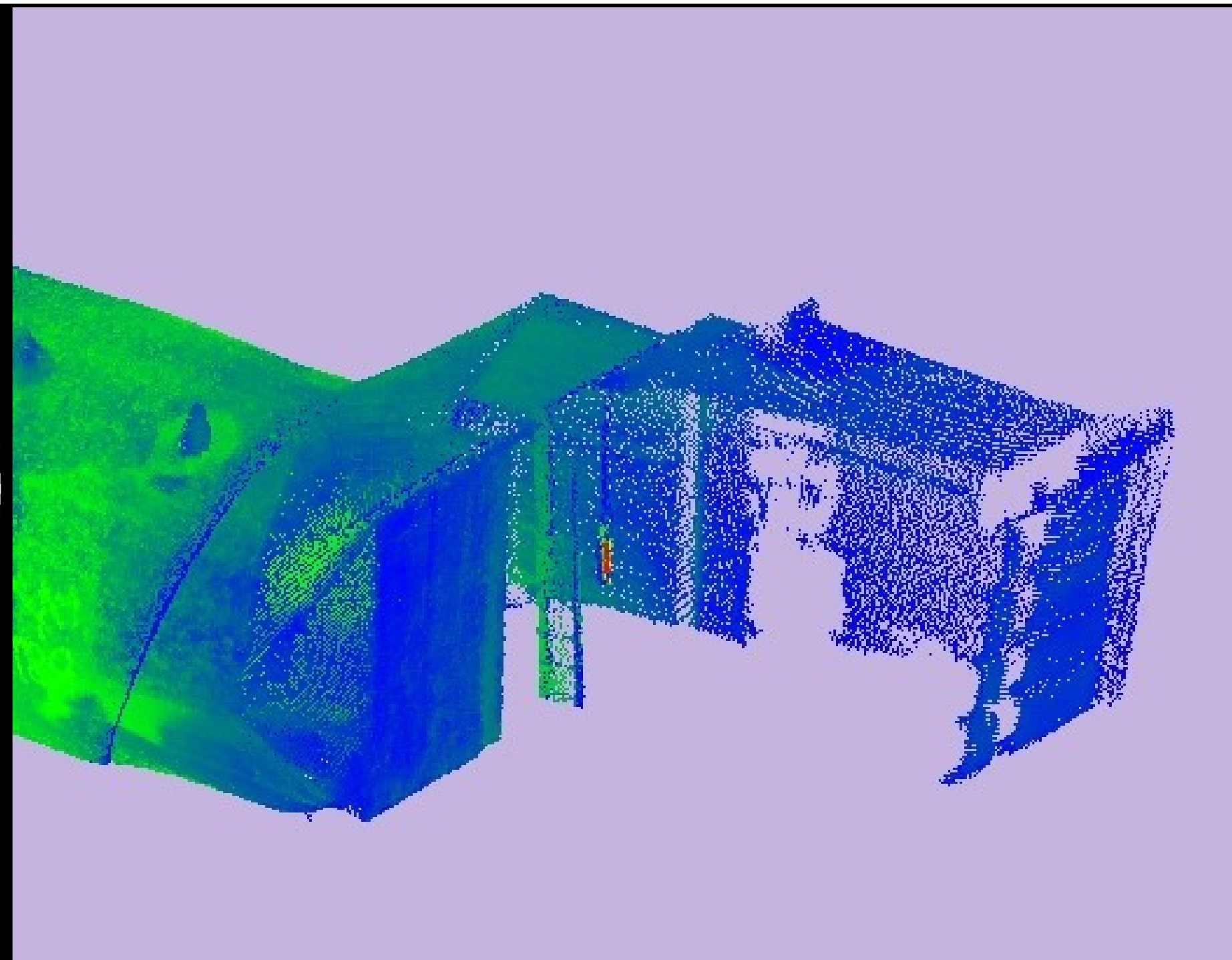
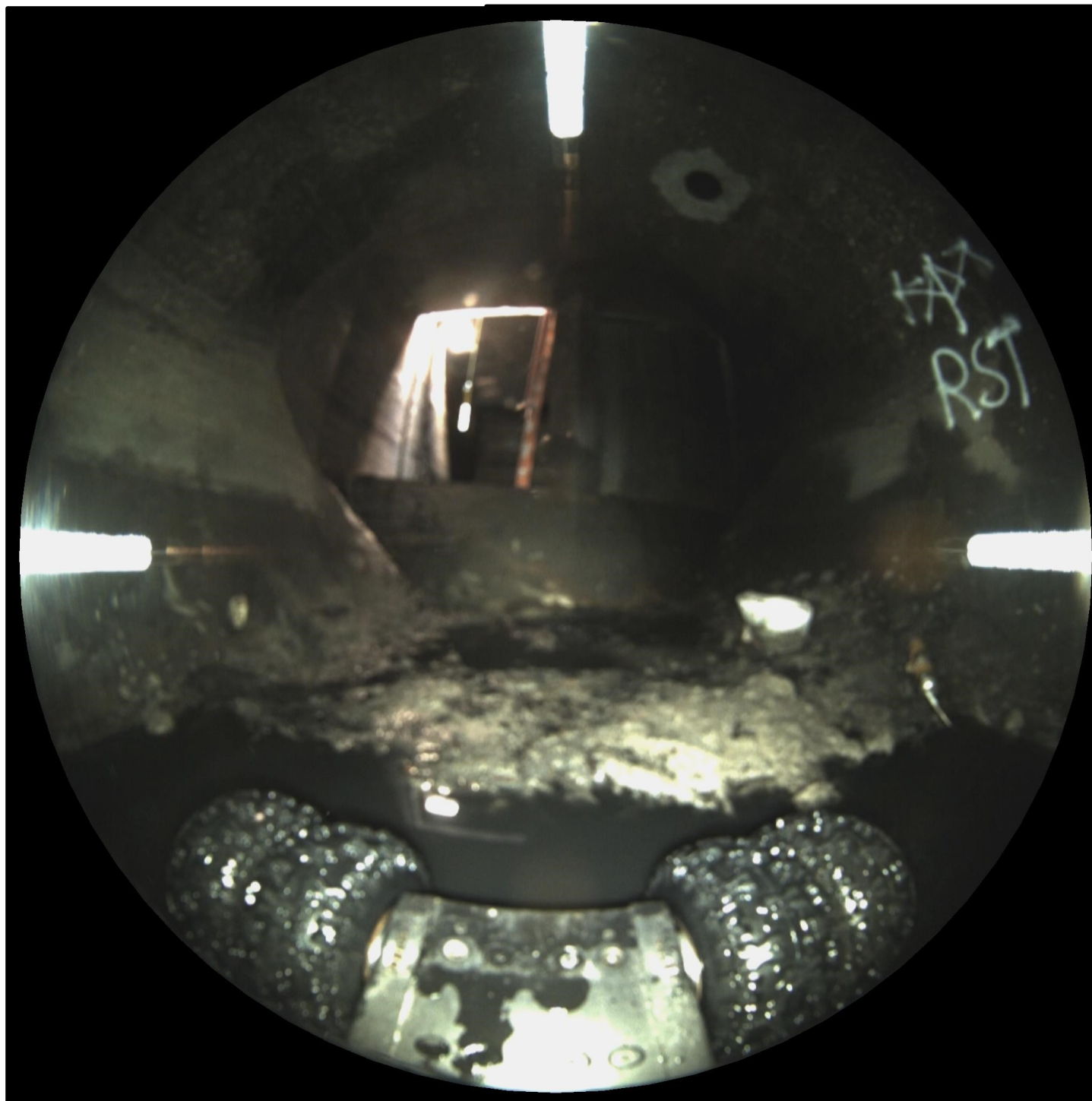

Detroit, MI – B39 OUTFALL

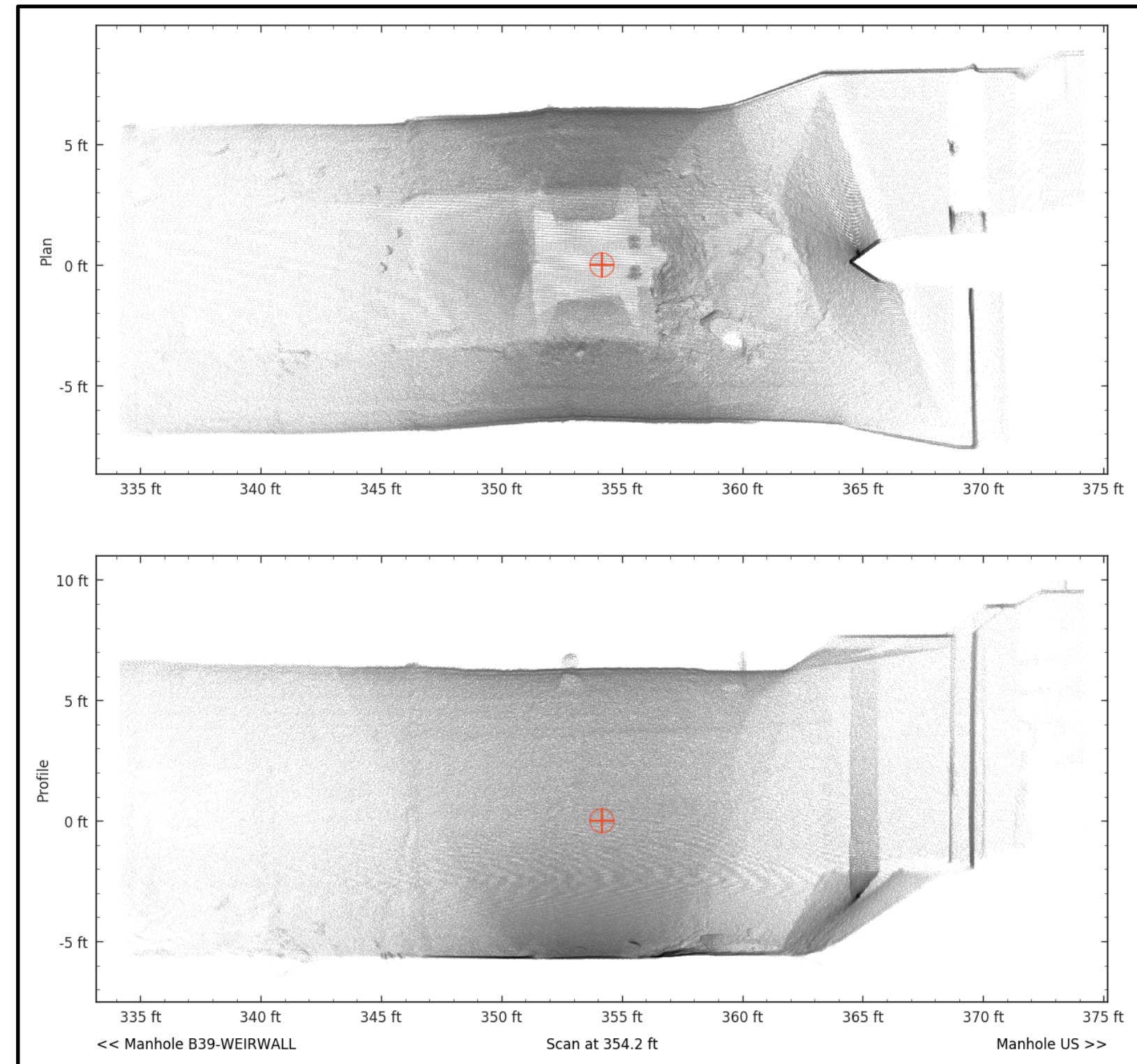
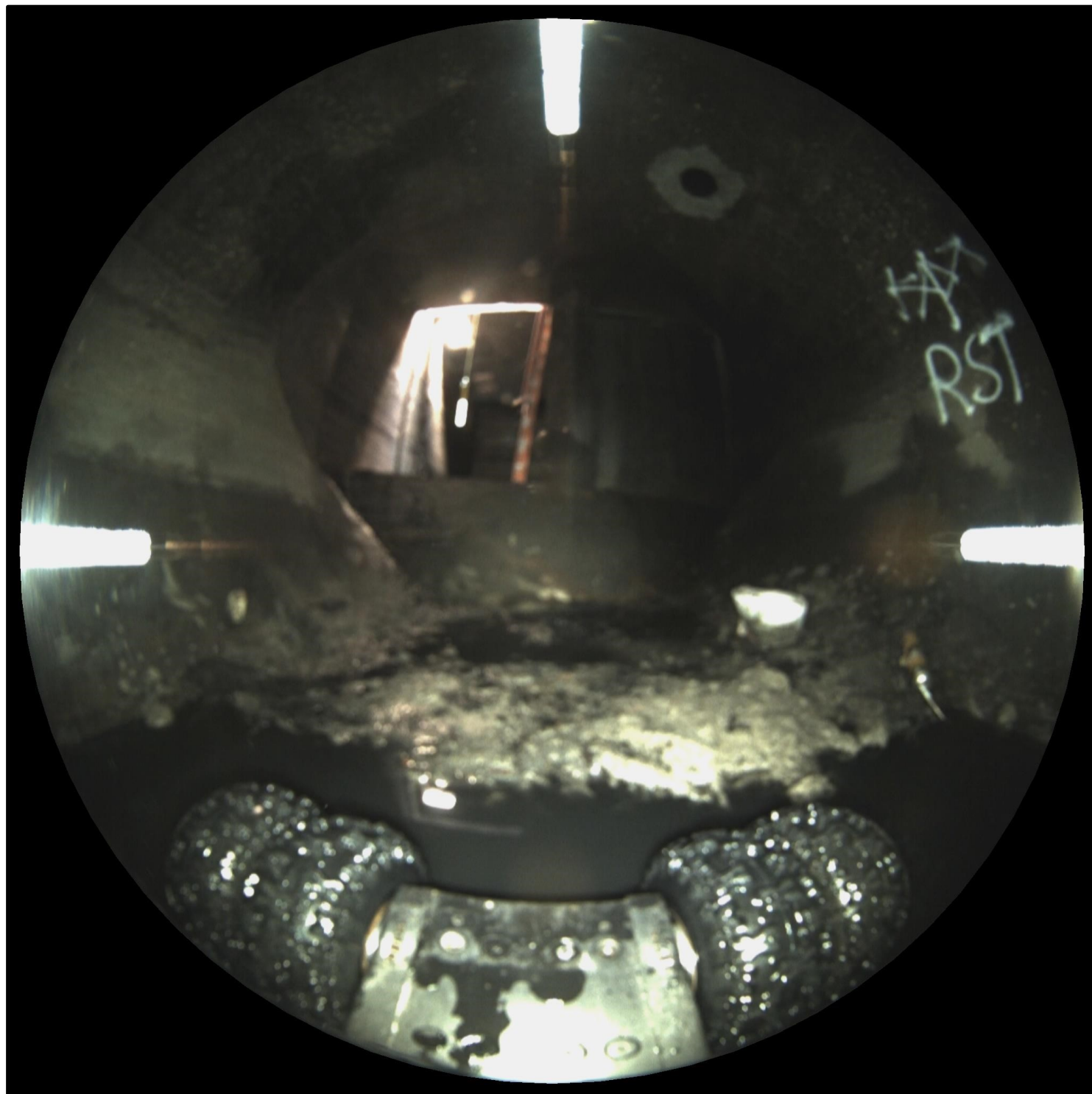

Detroit, MI – B39 OUTFALL



Detroit, MI – B39 OUTFALL

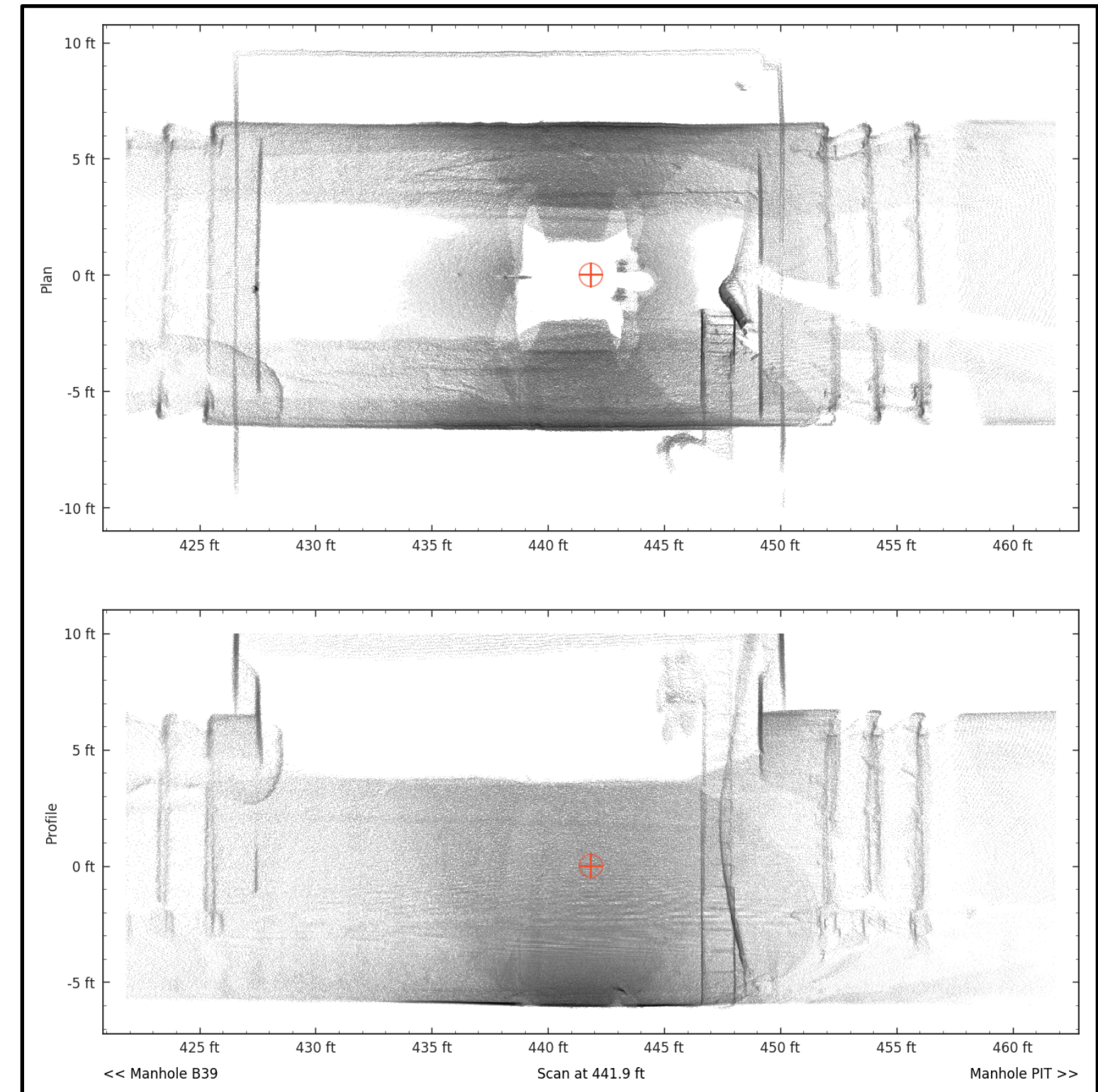

Detroit, MI – B39 OUTFALL

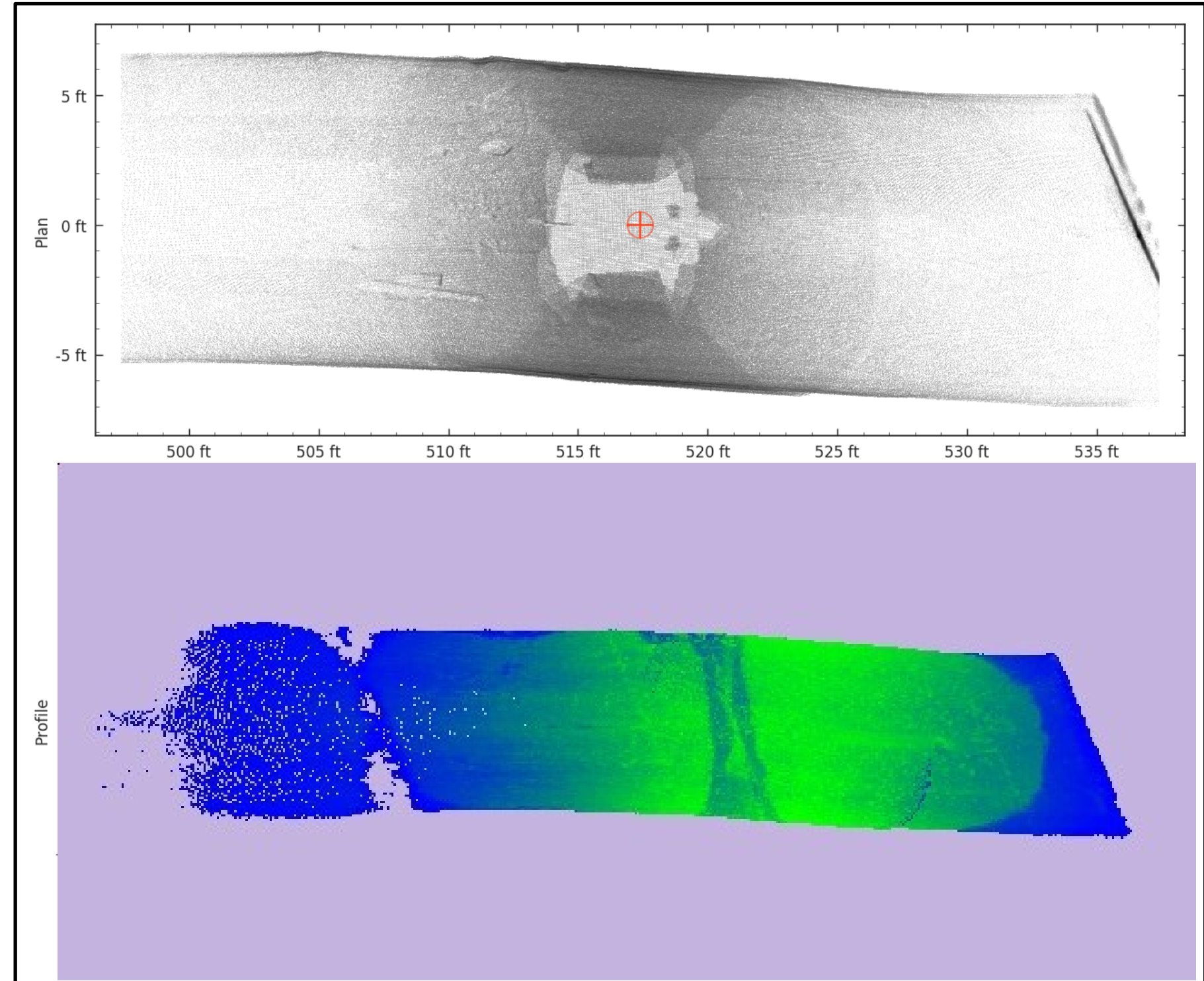
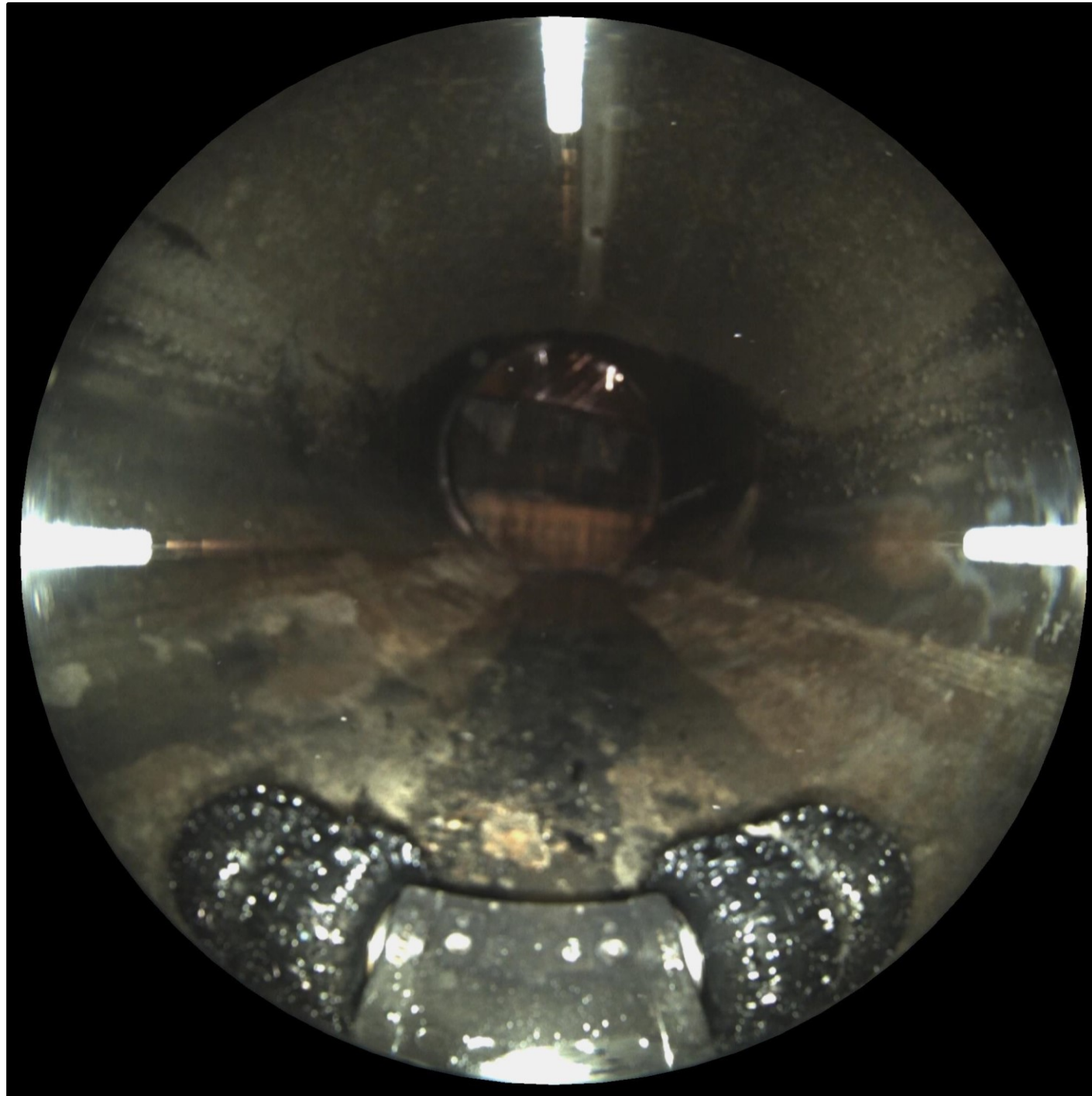

Detroit, MI – B39 OUTFALL

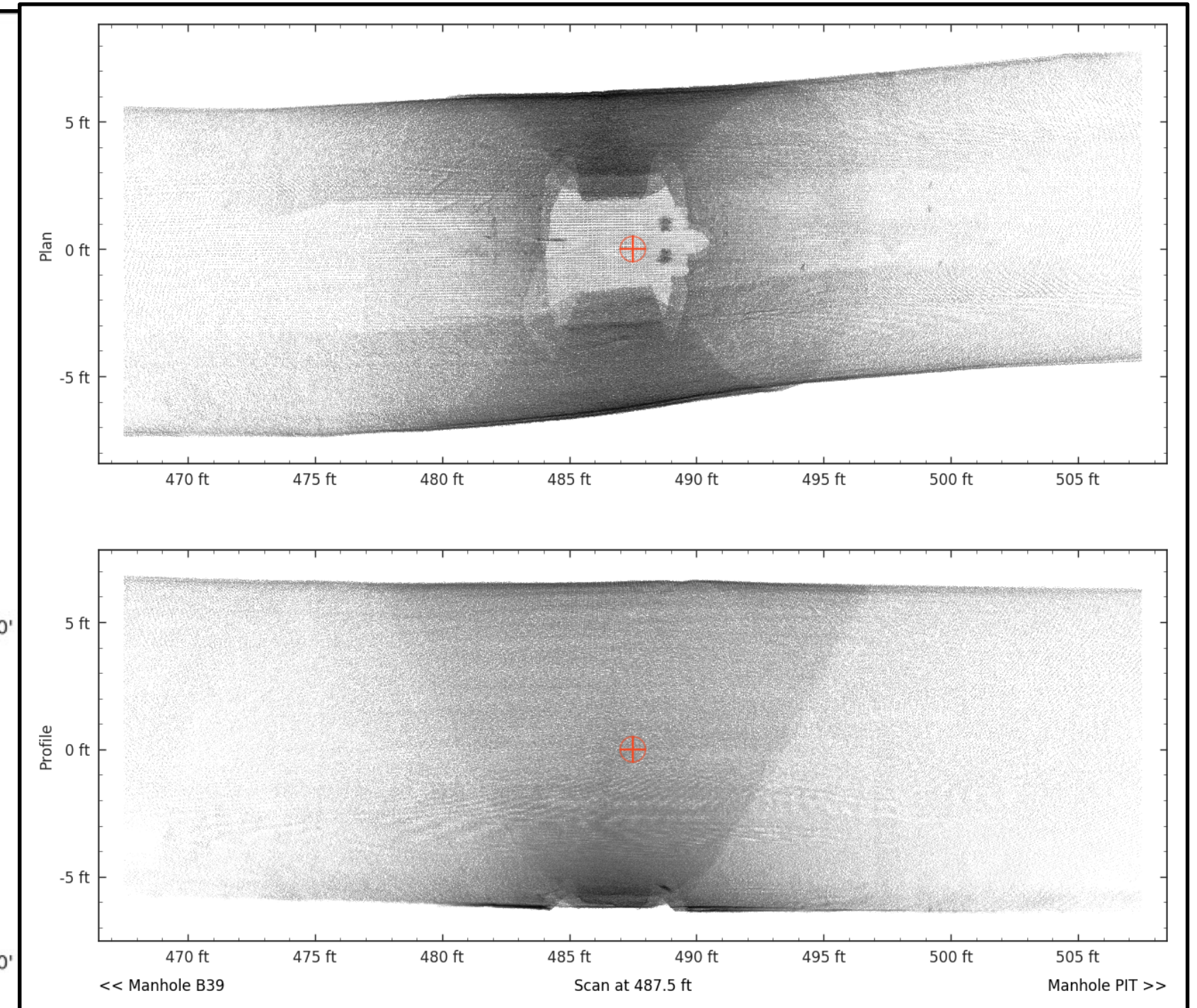
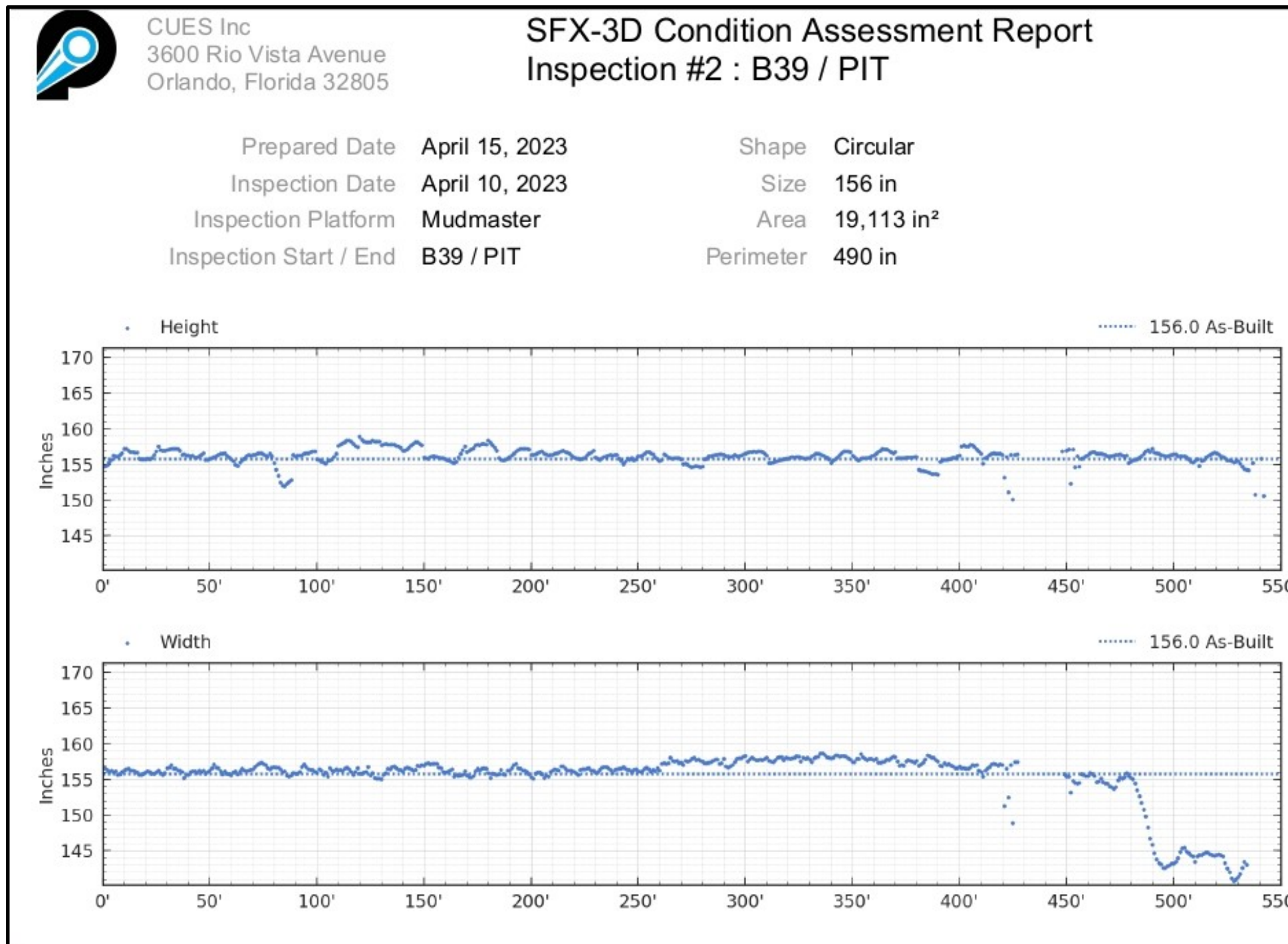

Detroit, MI – B39

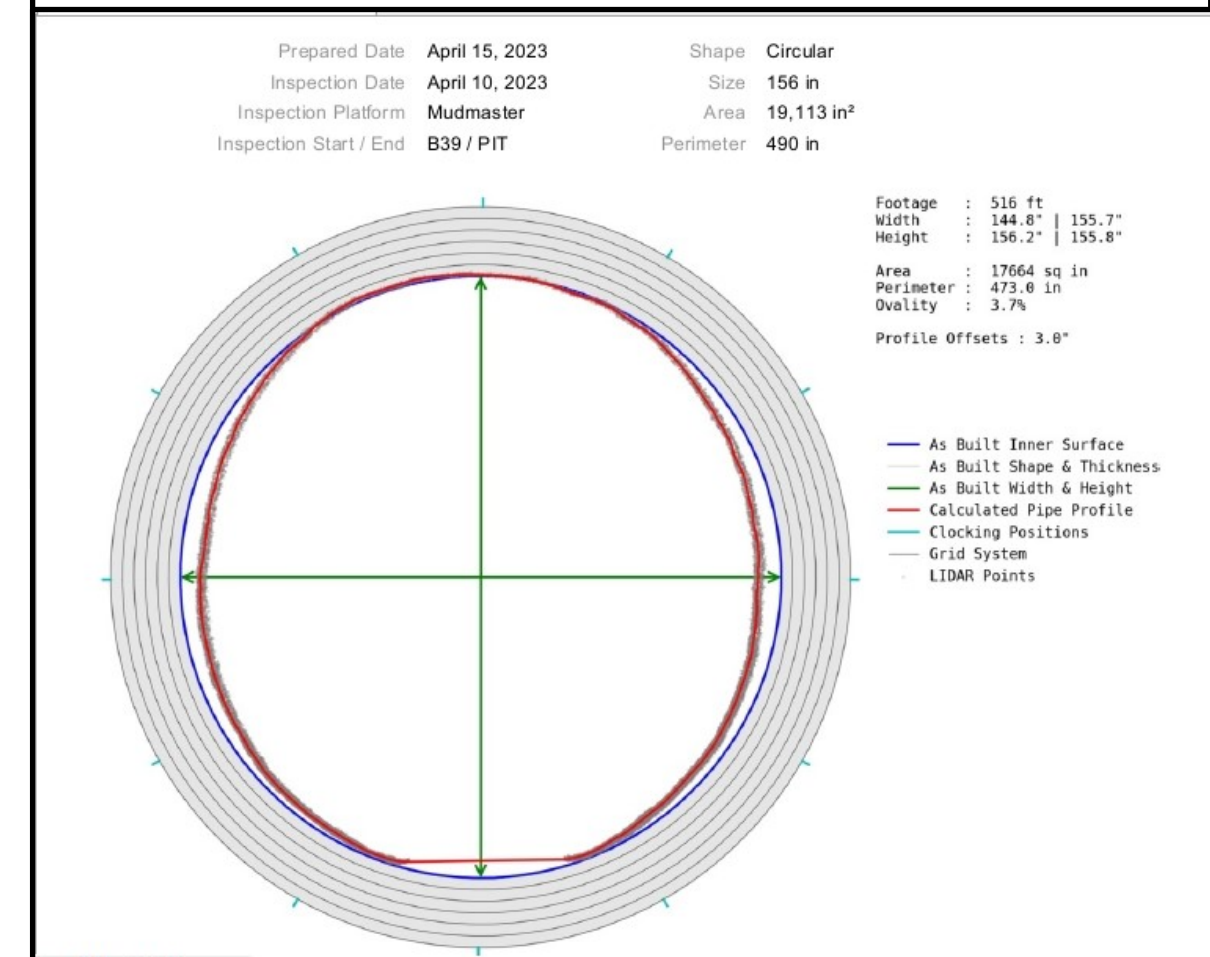
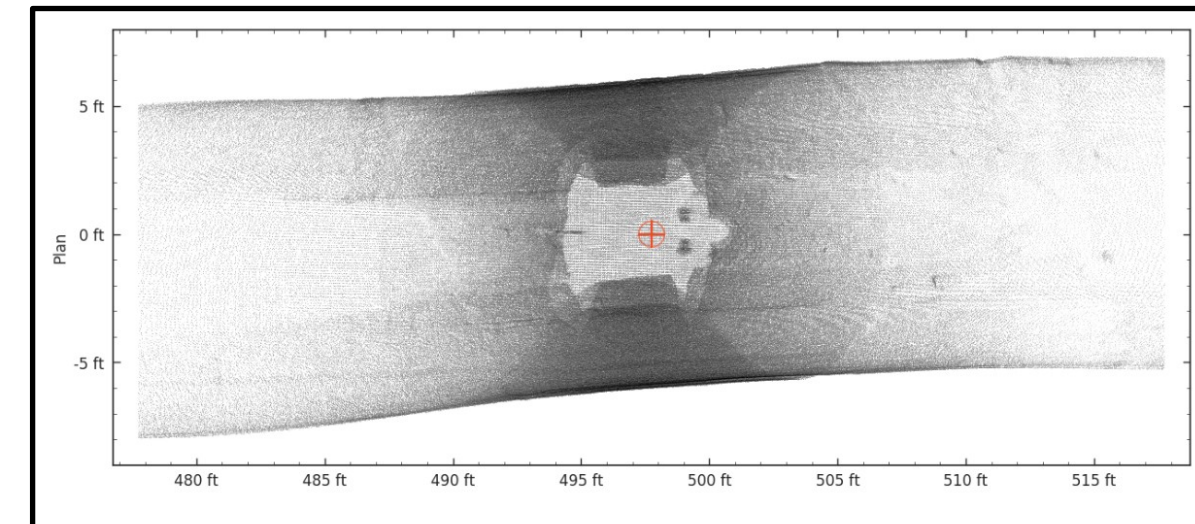
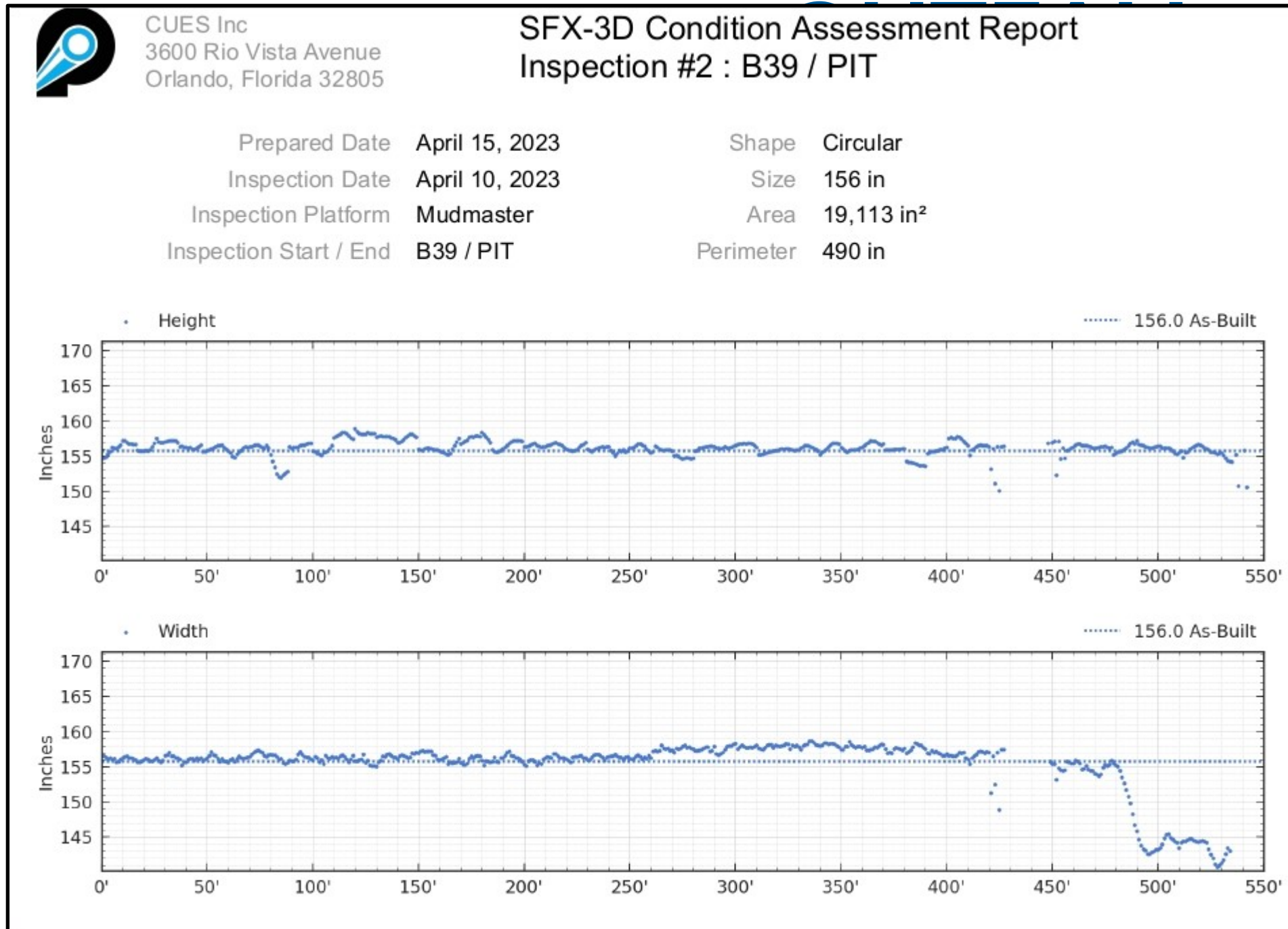

Detroit, MI – B39

Bend Report -B39 to WEIR

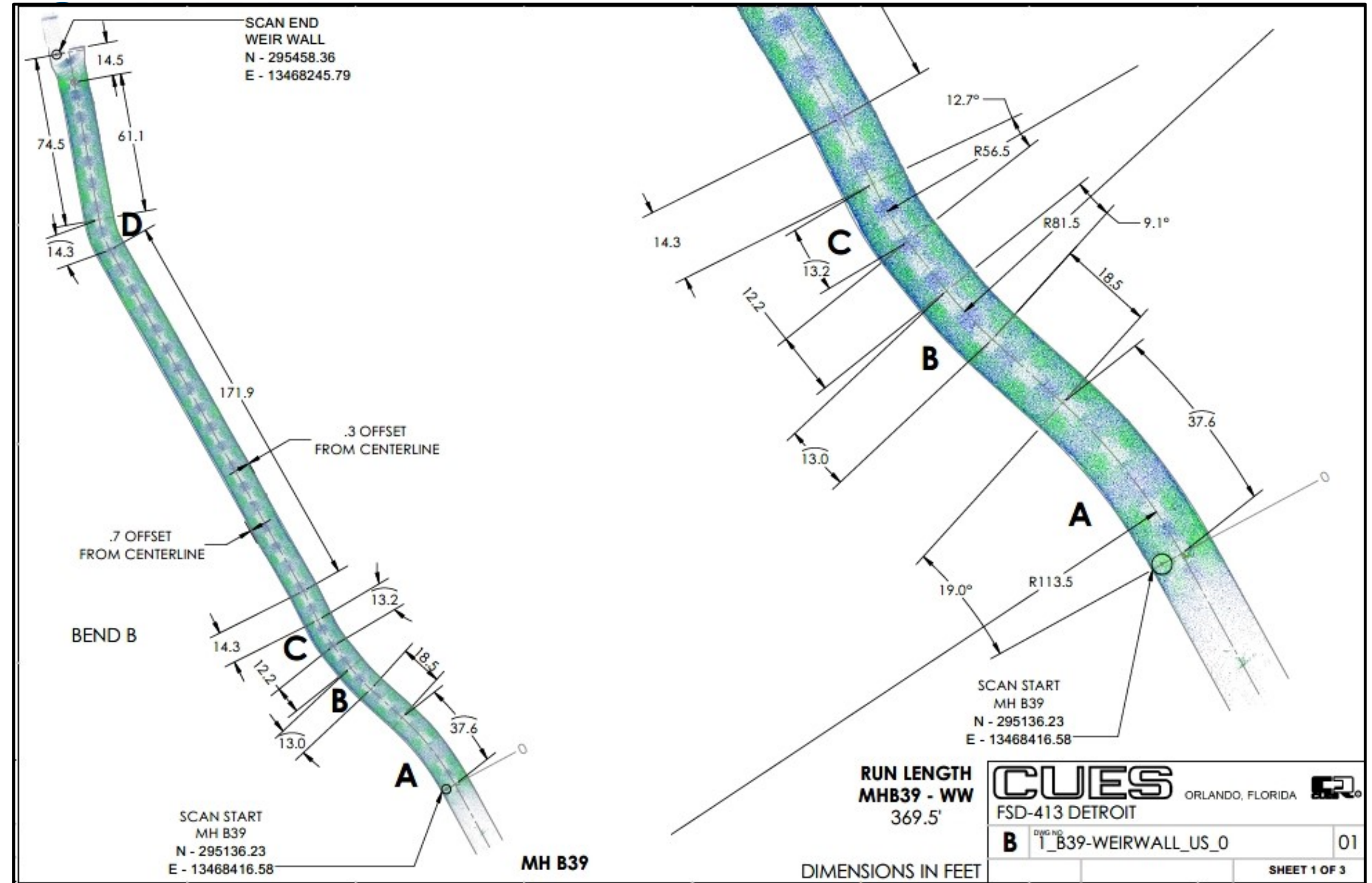
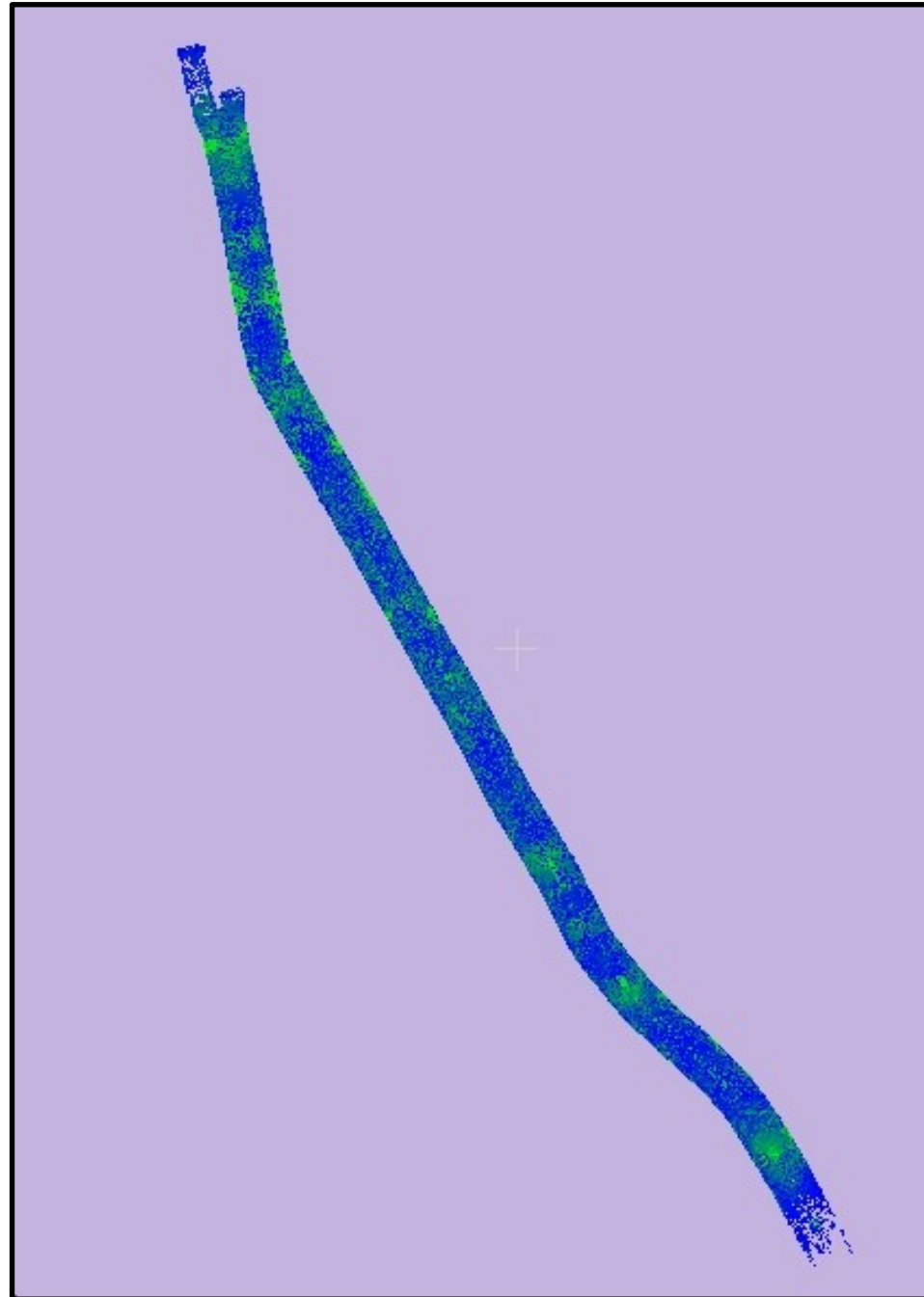

Detroit, MI – B39

Centerline Report B39 to WEIR WALL

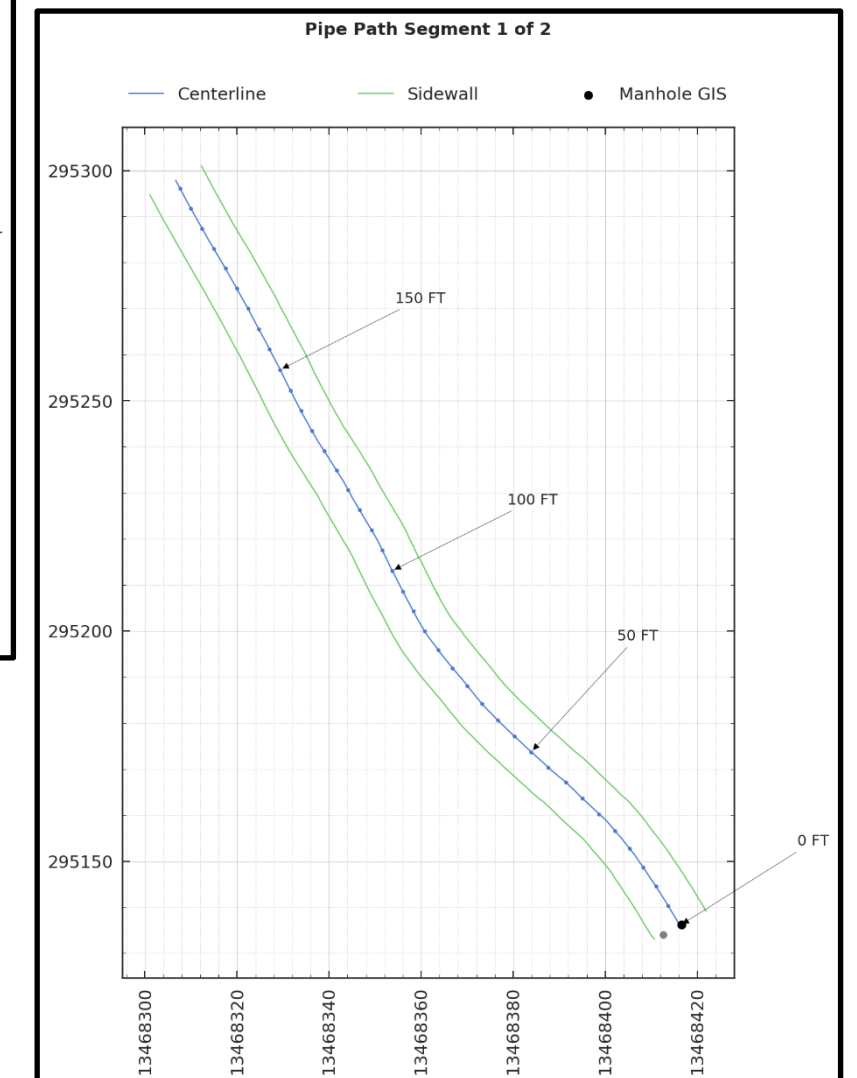
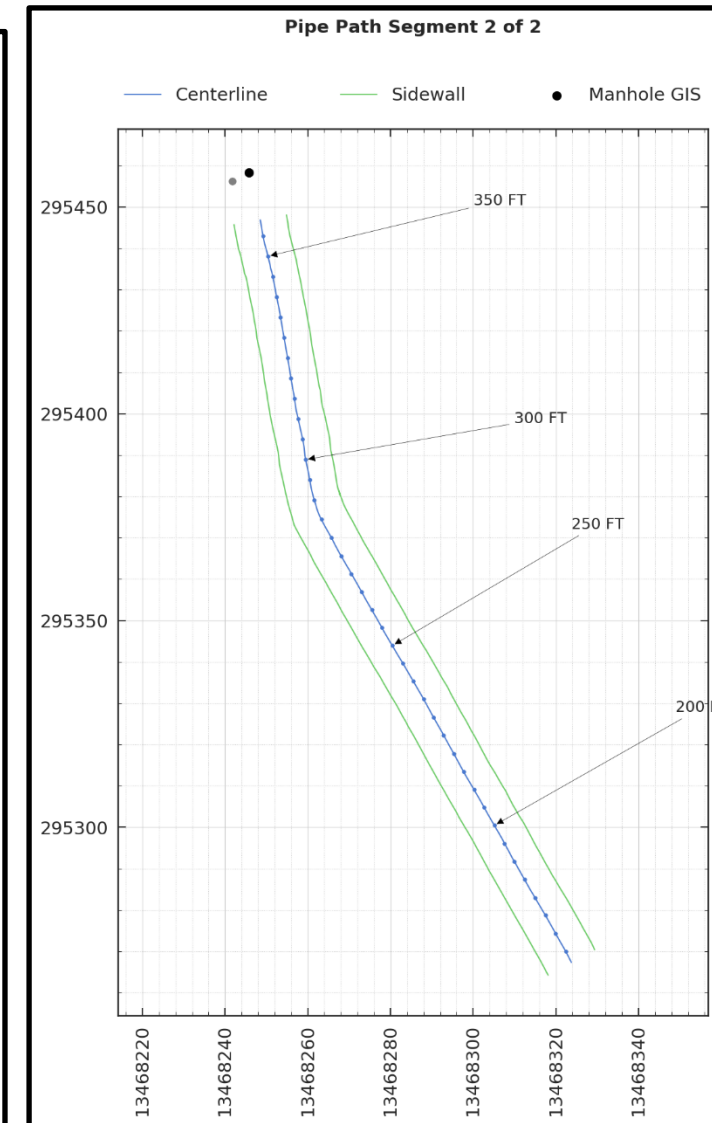
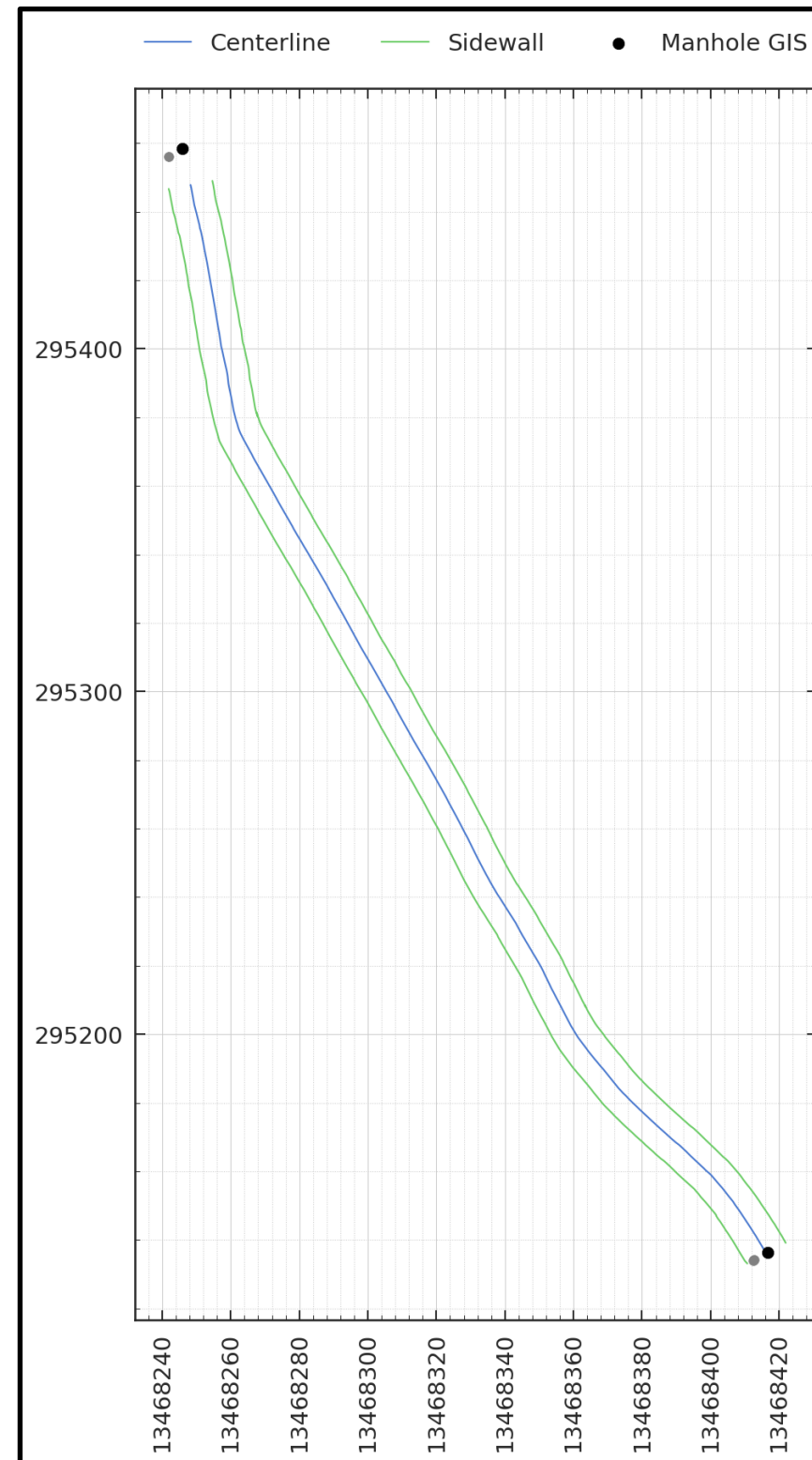
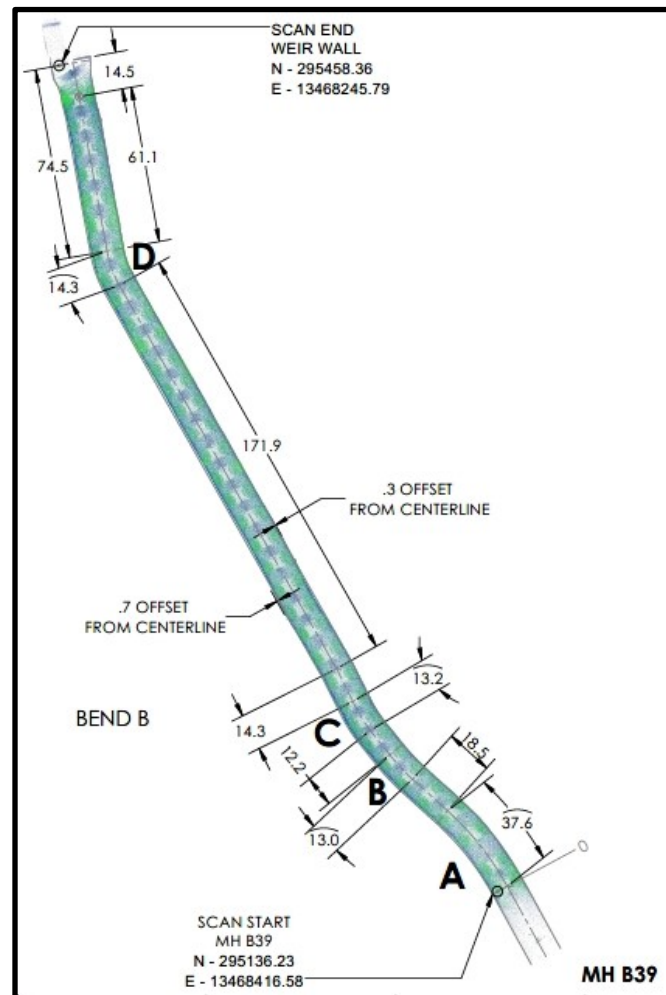

Detroit, MI – B39 OUTFALL

Bend Report - B39 to PIT

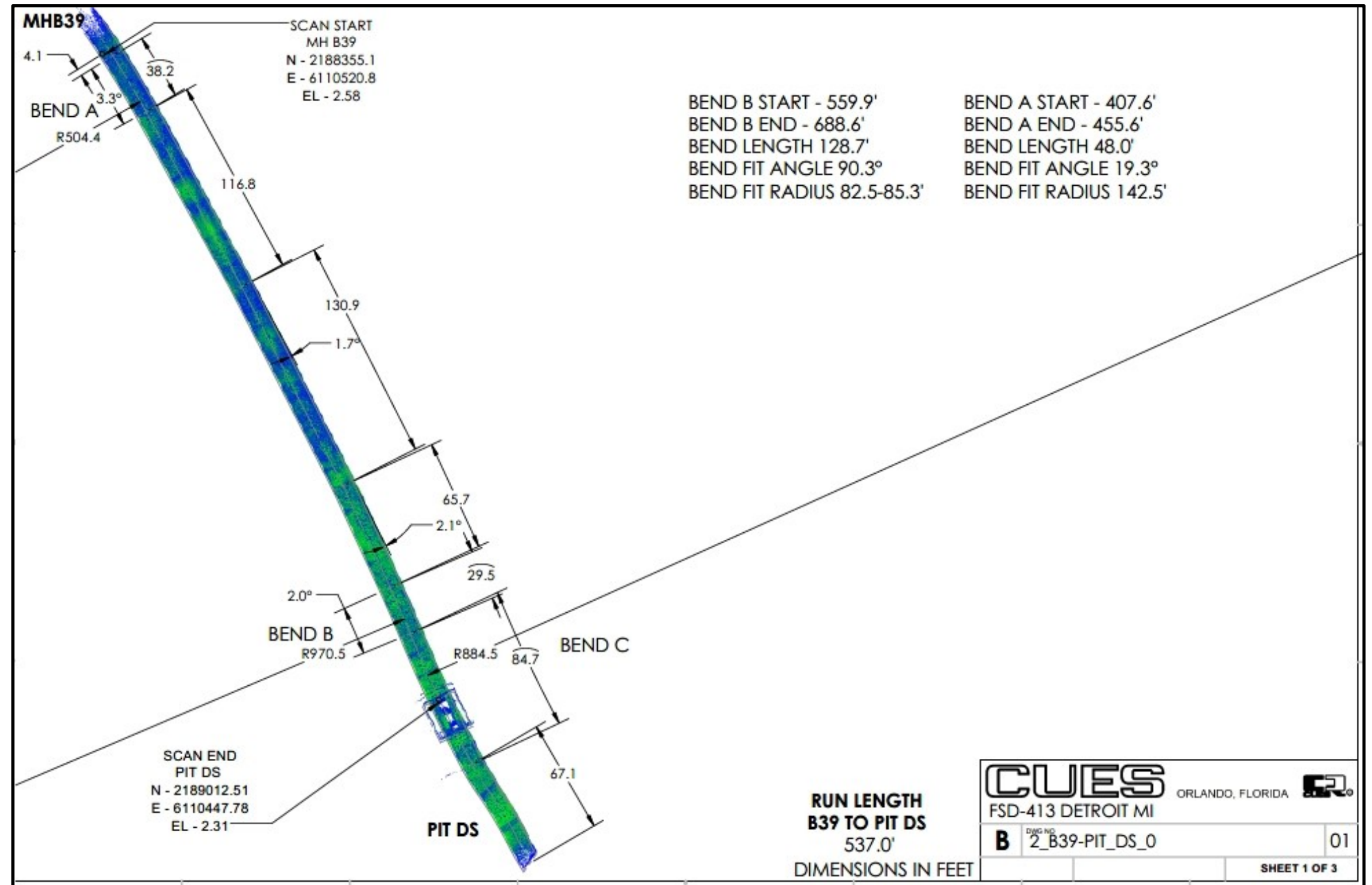
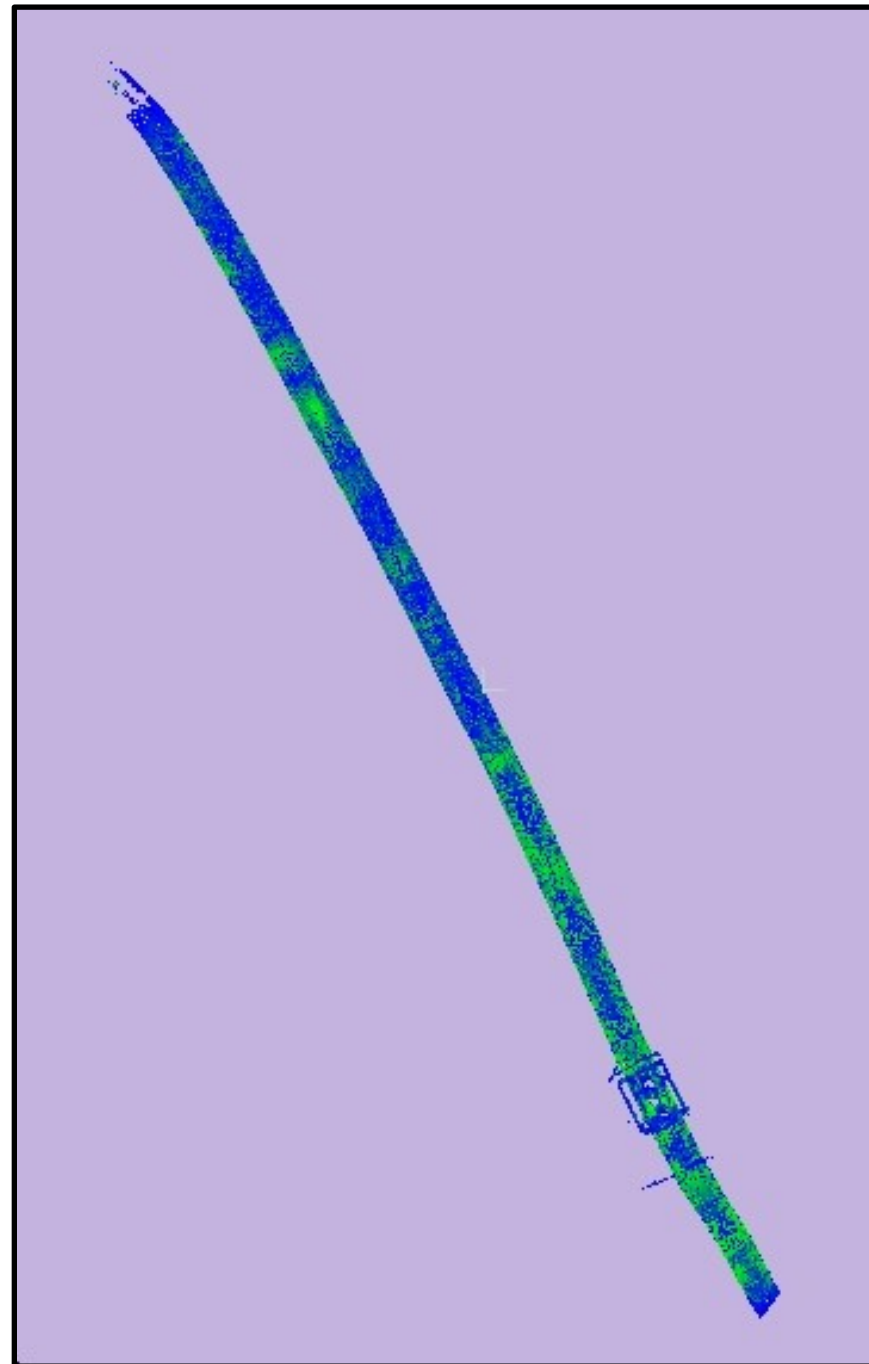

Detroit, MI - B39 OUTFALL

Centerline Report - B39 to PIT

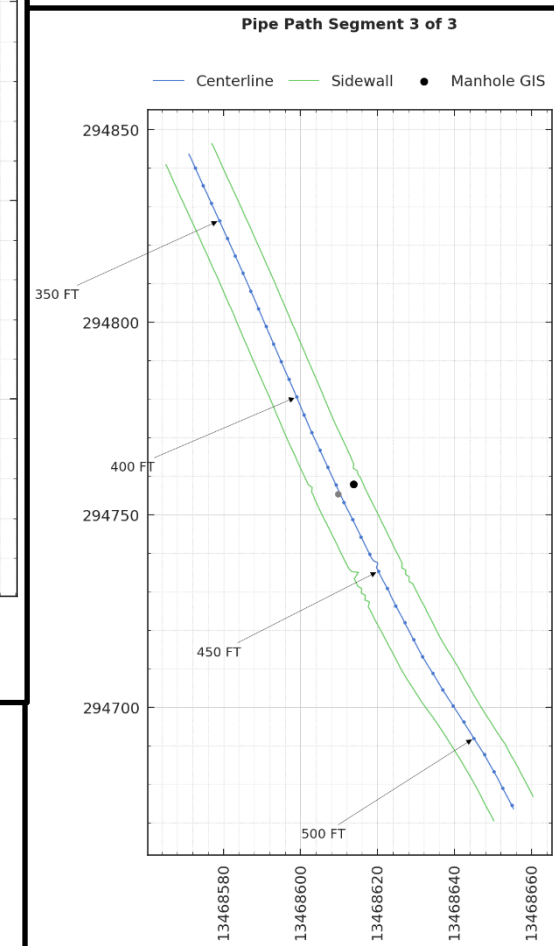
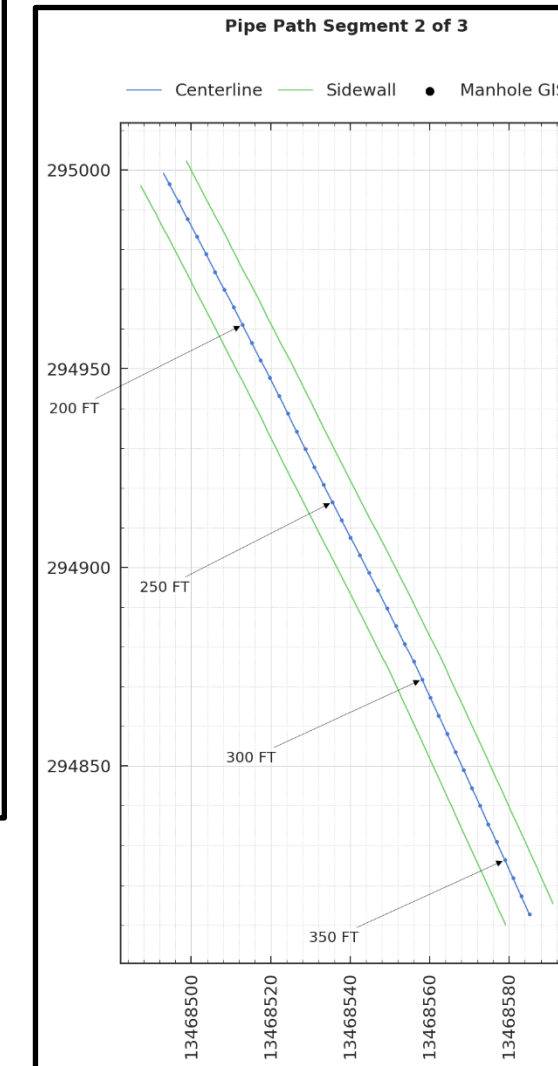
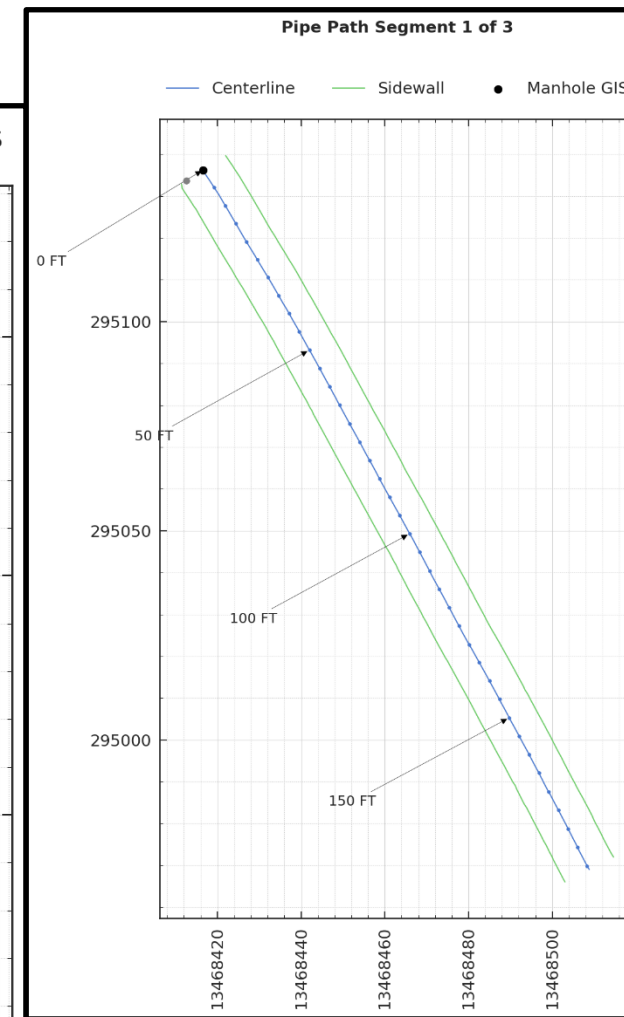
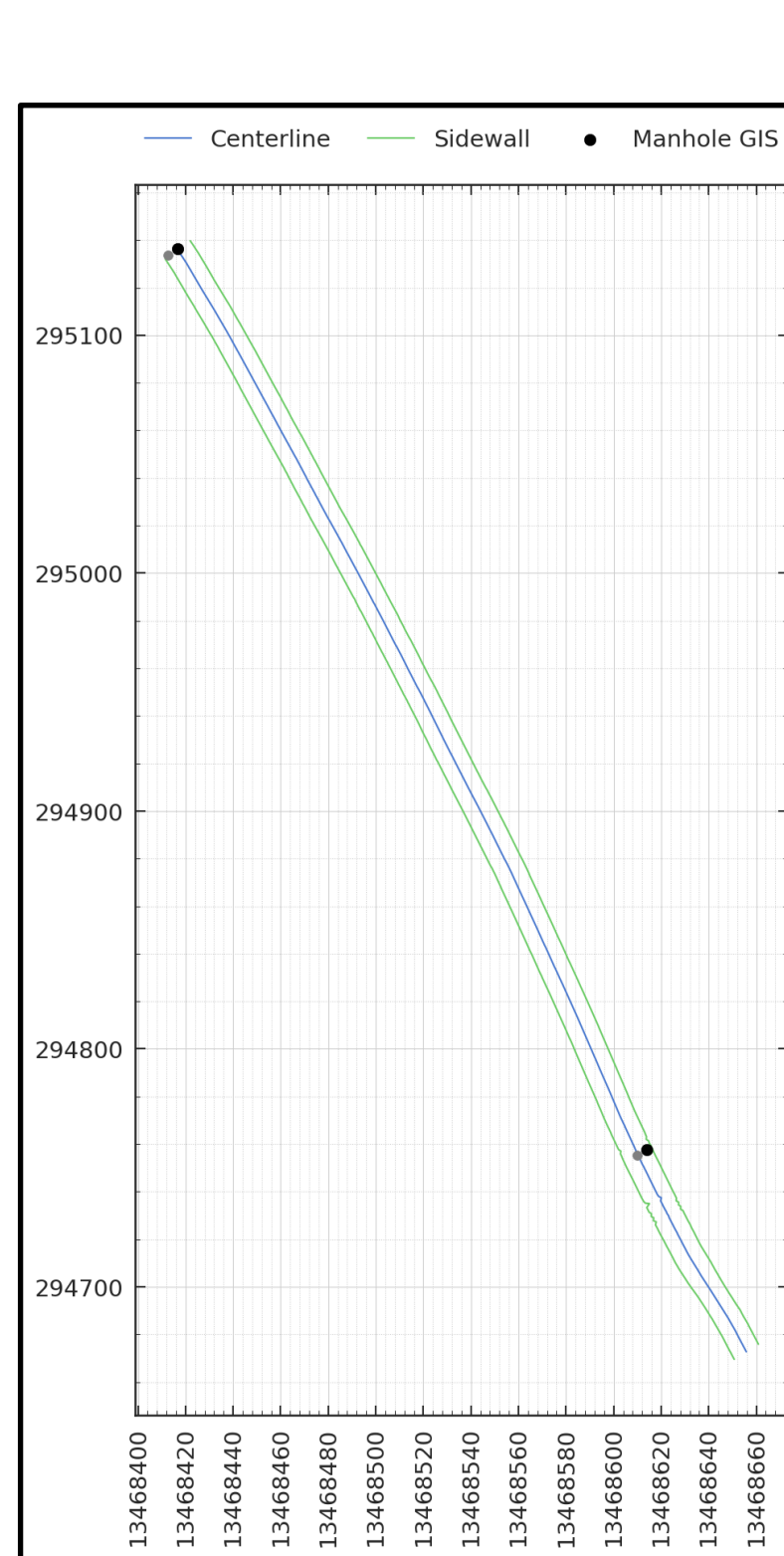
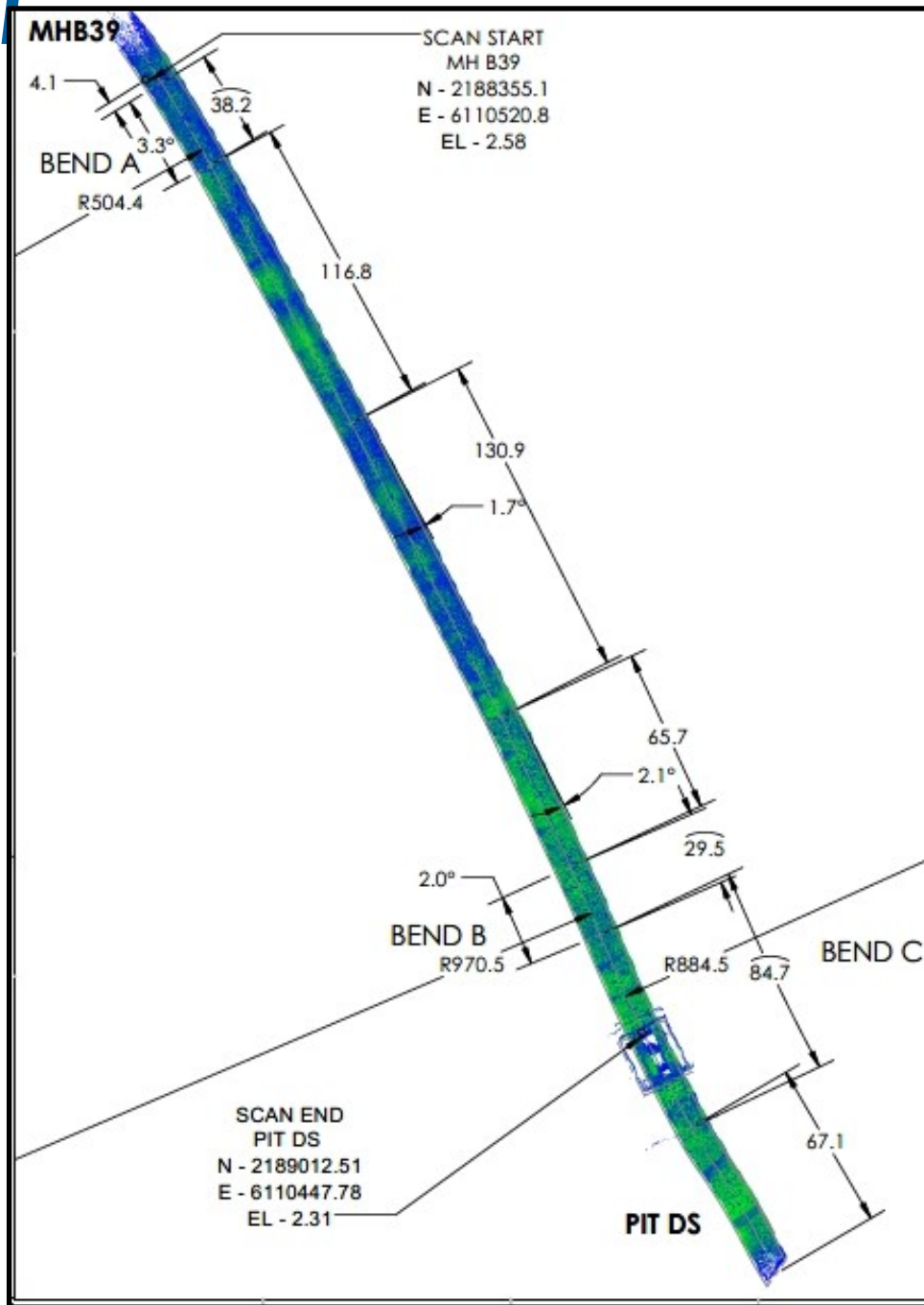

Detroit, MI – B39

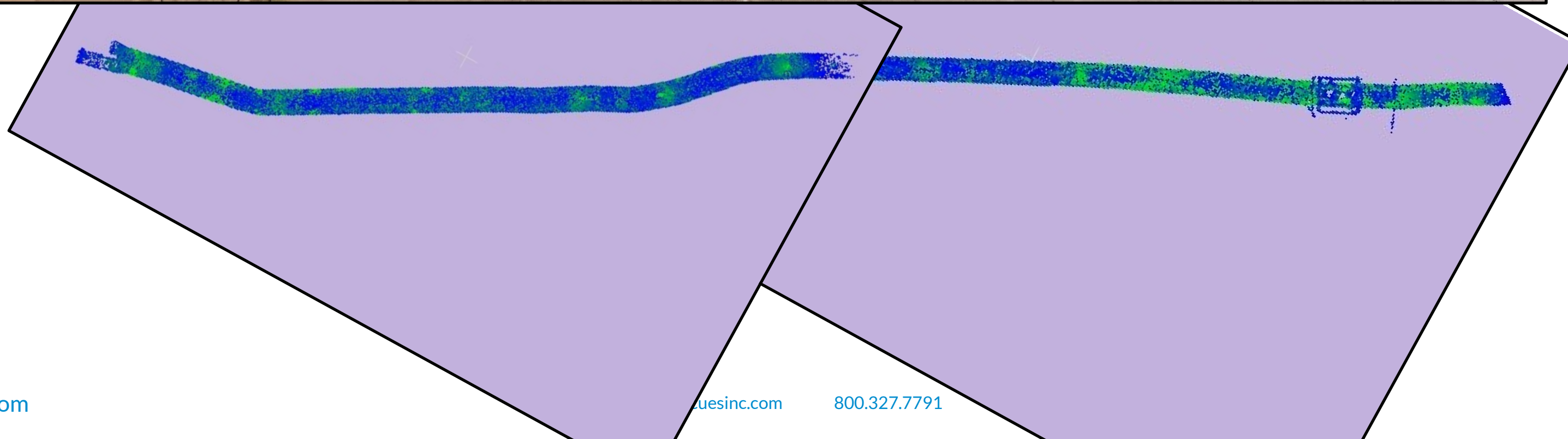
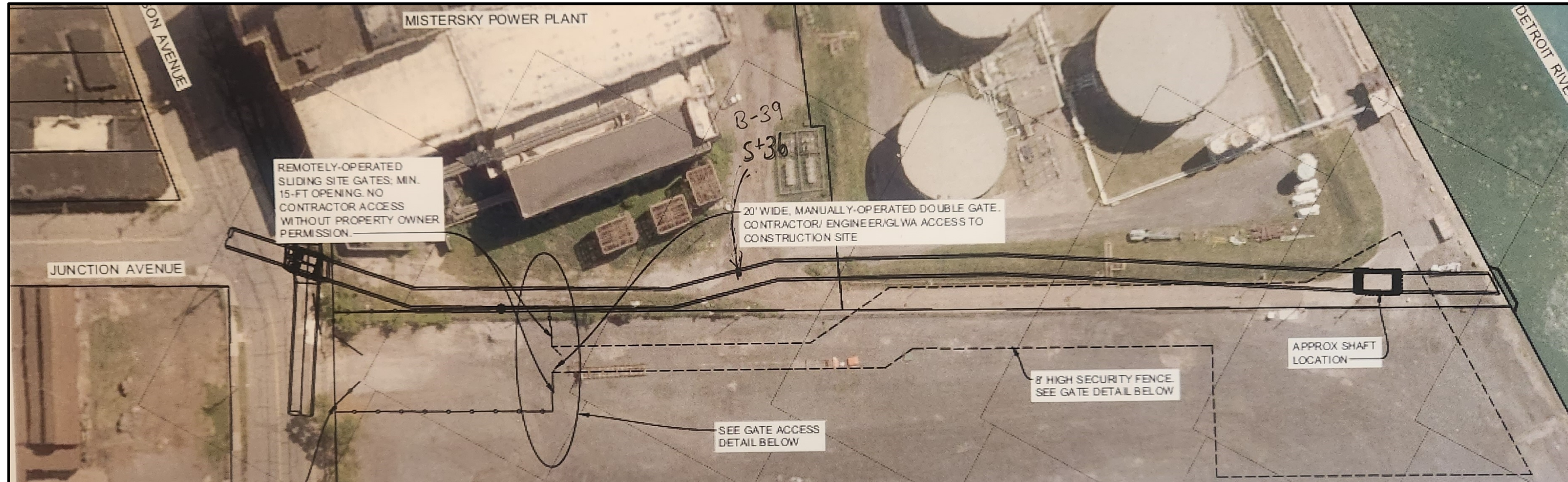

Detroit, MI – B39 OUTFALL

LAY PLAN

120" HOBAS Pipe

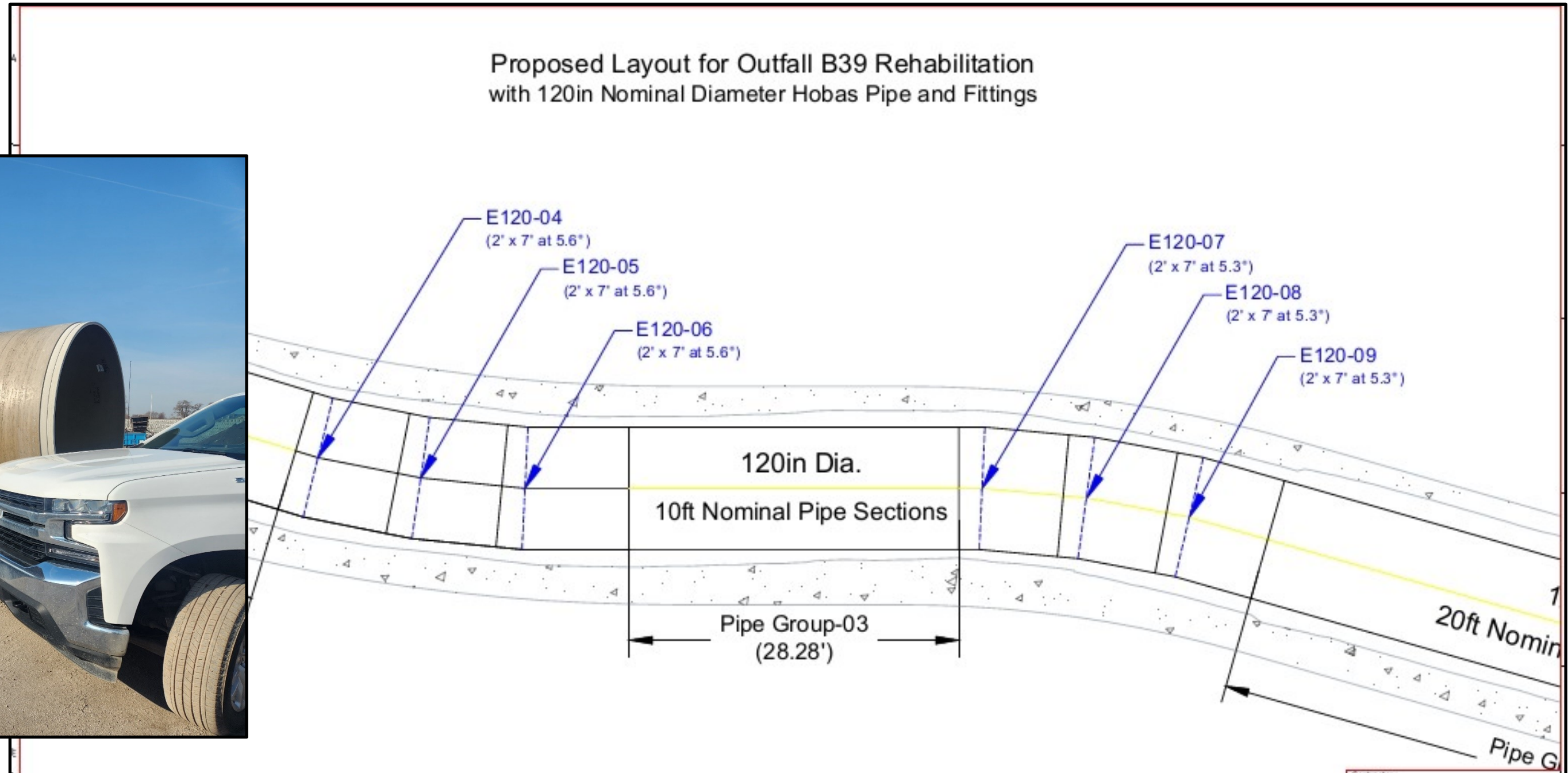

Detroit, MI – Woodward Rehab

Woodward Sewer Rehab

Size & Bend Analysis &
Geolocation

CIRC SHAPED PIPE
FIELD WORK - SEPT 2022

What is the geometry of the 90-deg bend at Woodward Ave.?

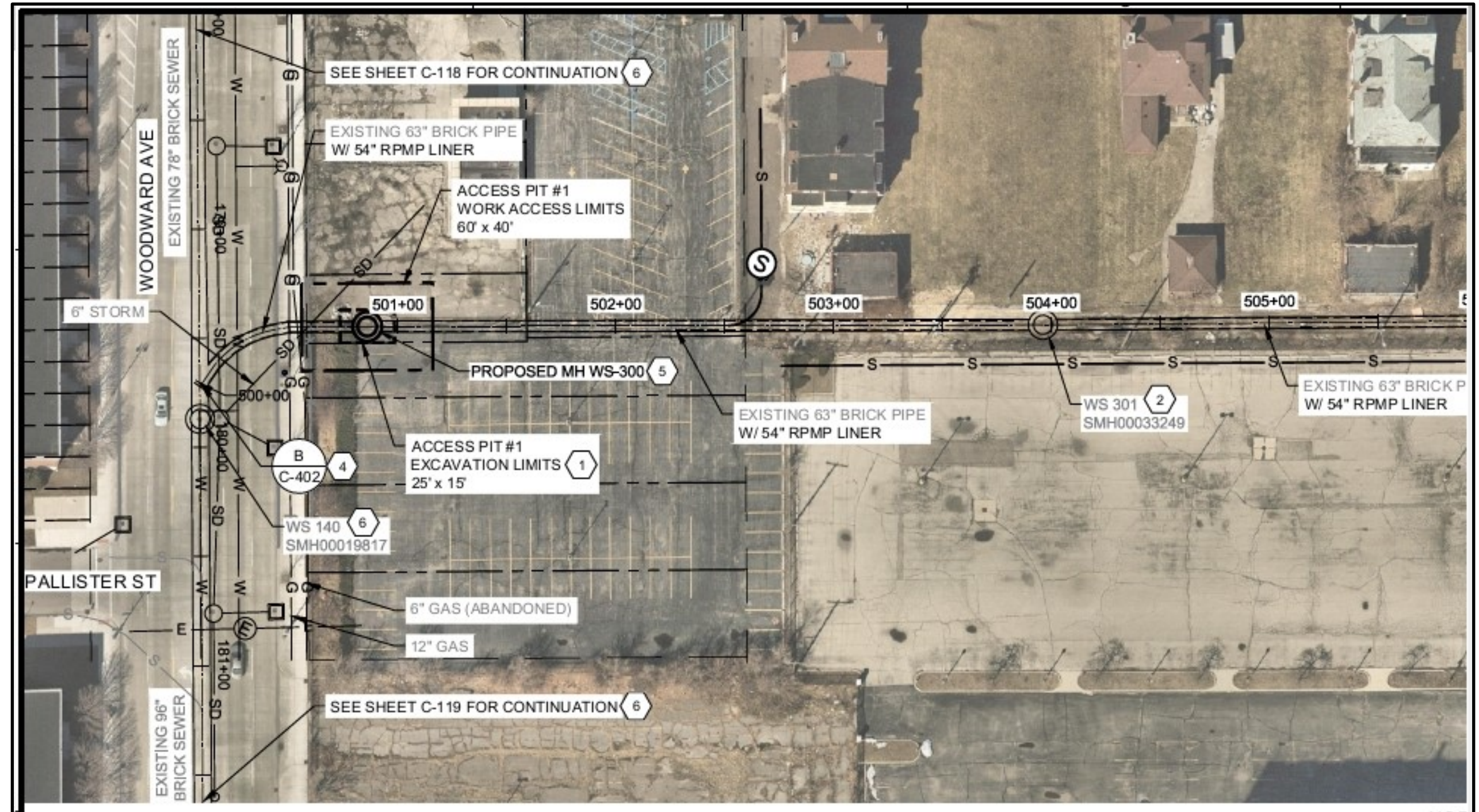

Detroit, MI – Woodward Rehab

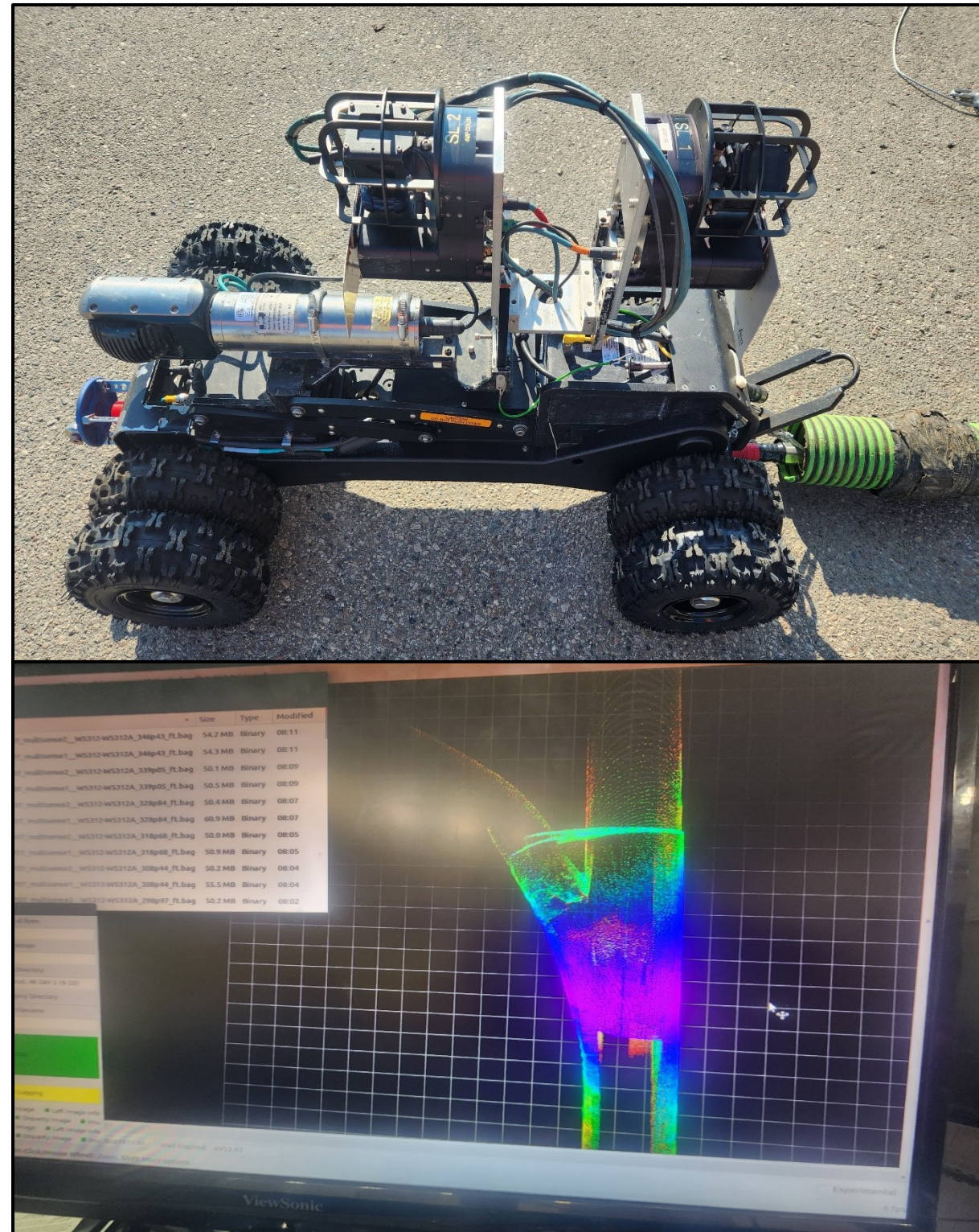

Detroit, MI – Woodward Rehab

CIRC - WS301 TO WS140 (Woodward Ave.)

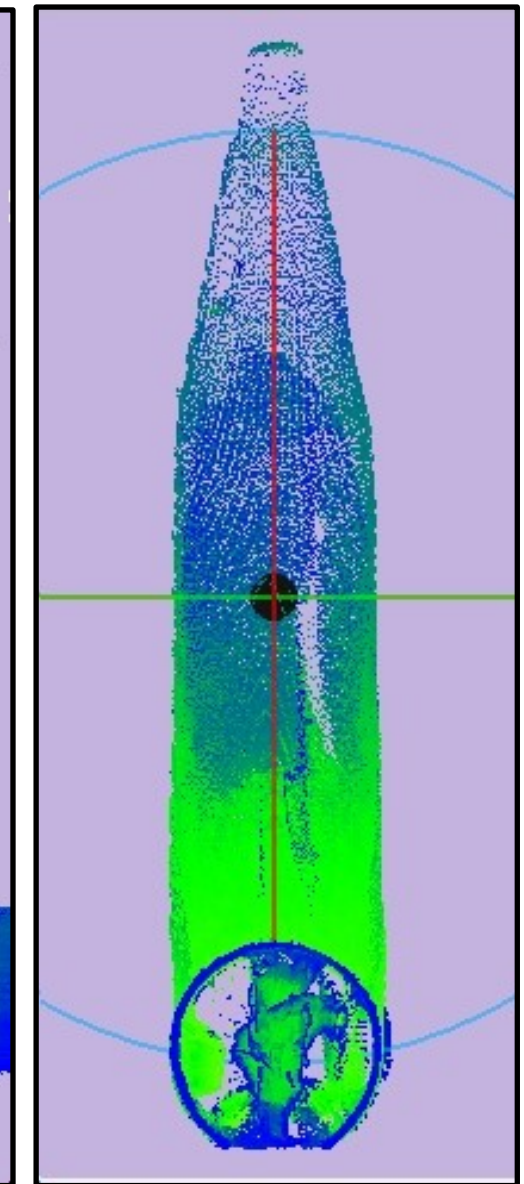
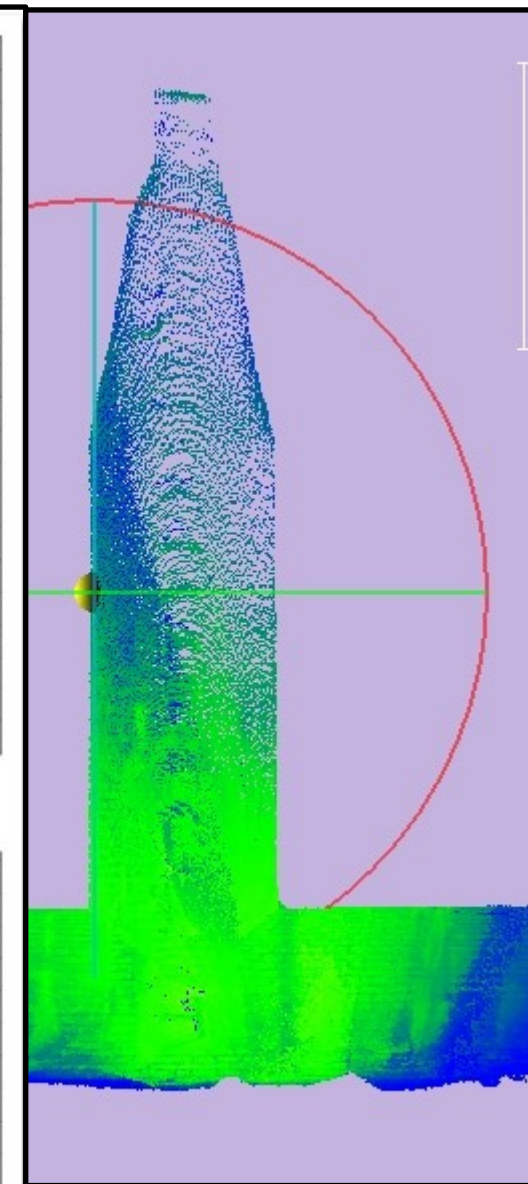
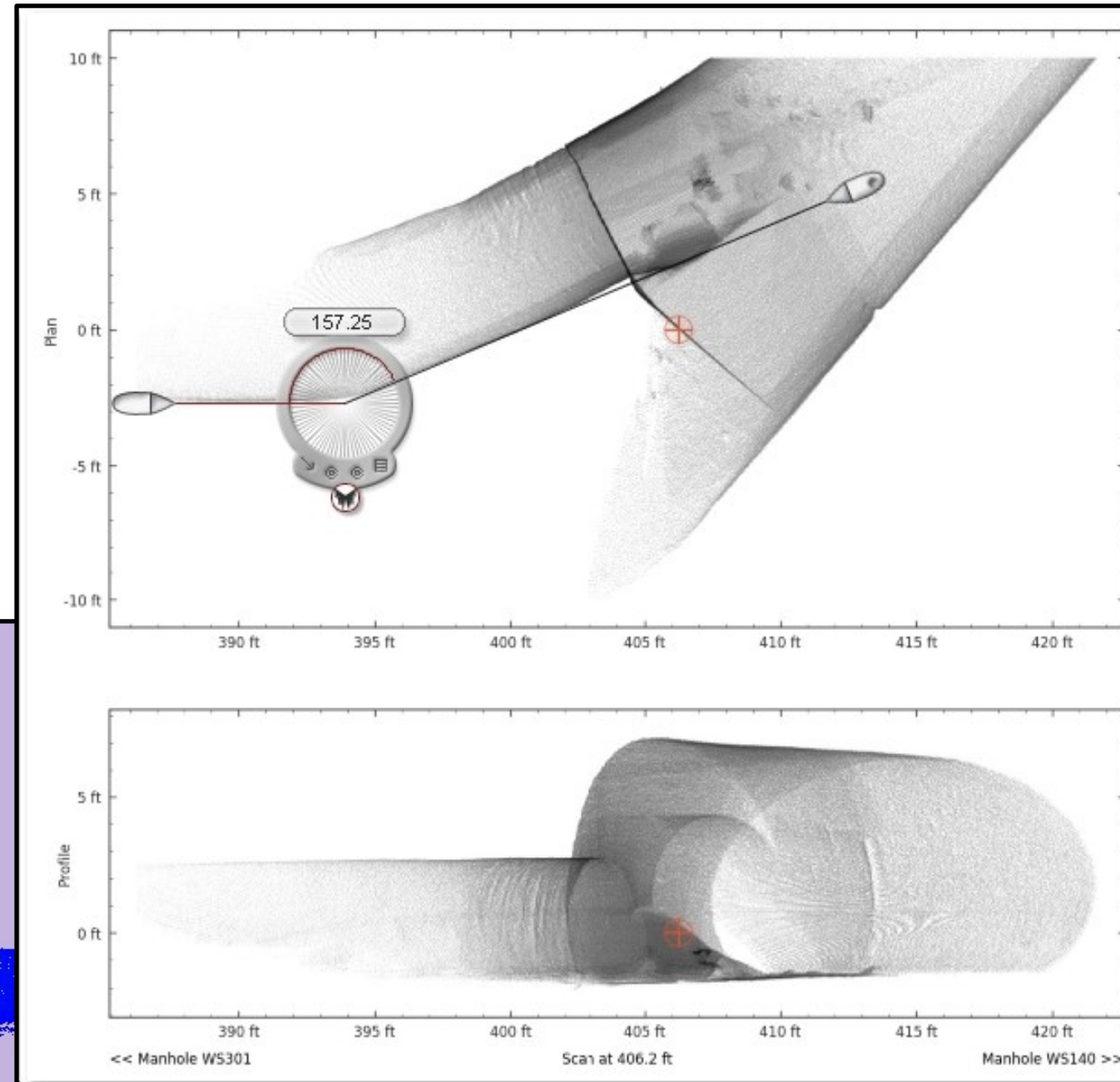
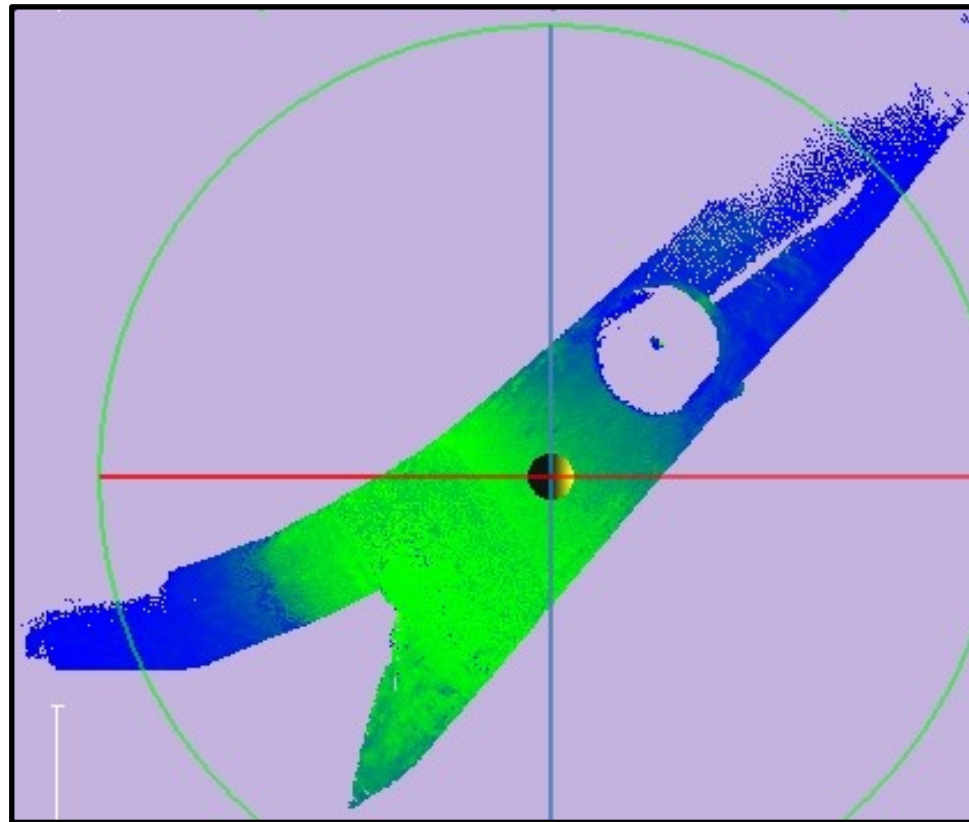

Detroit, MI – Woodward

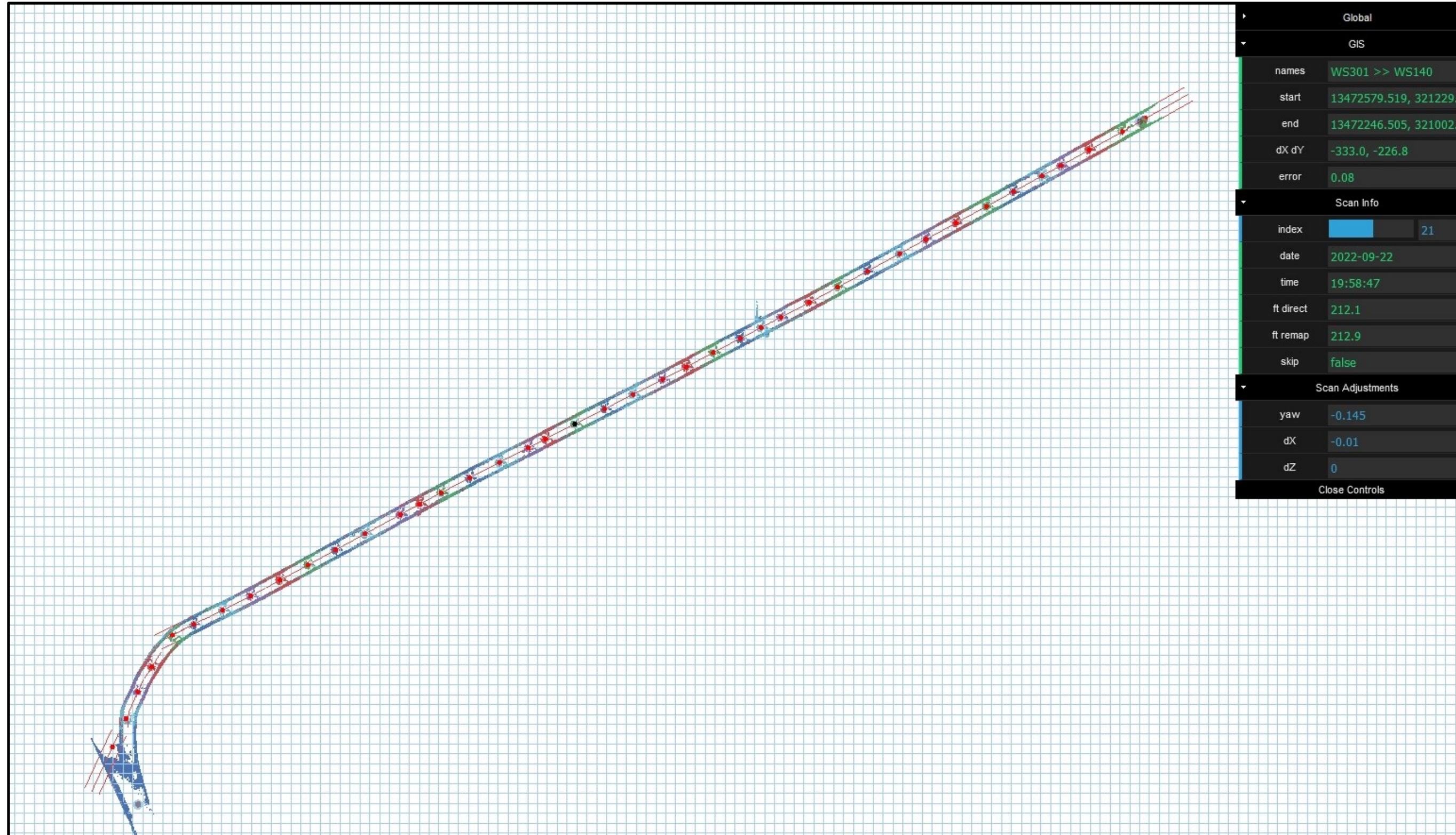

Detroit, MI - Woodward

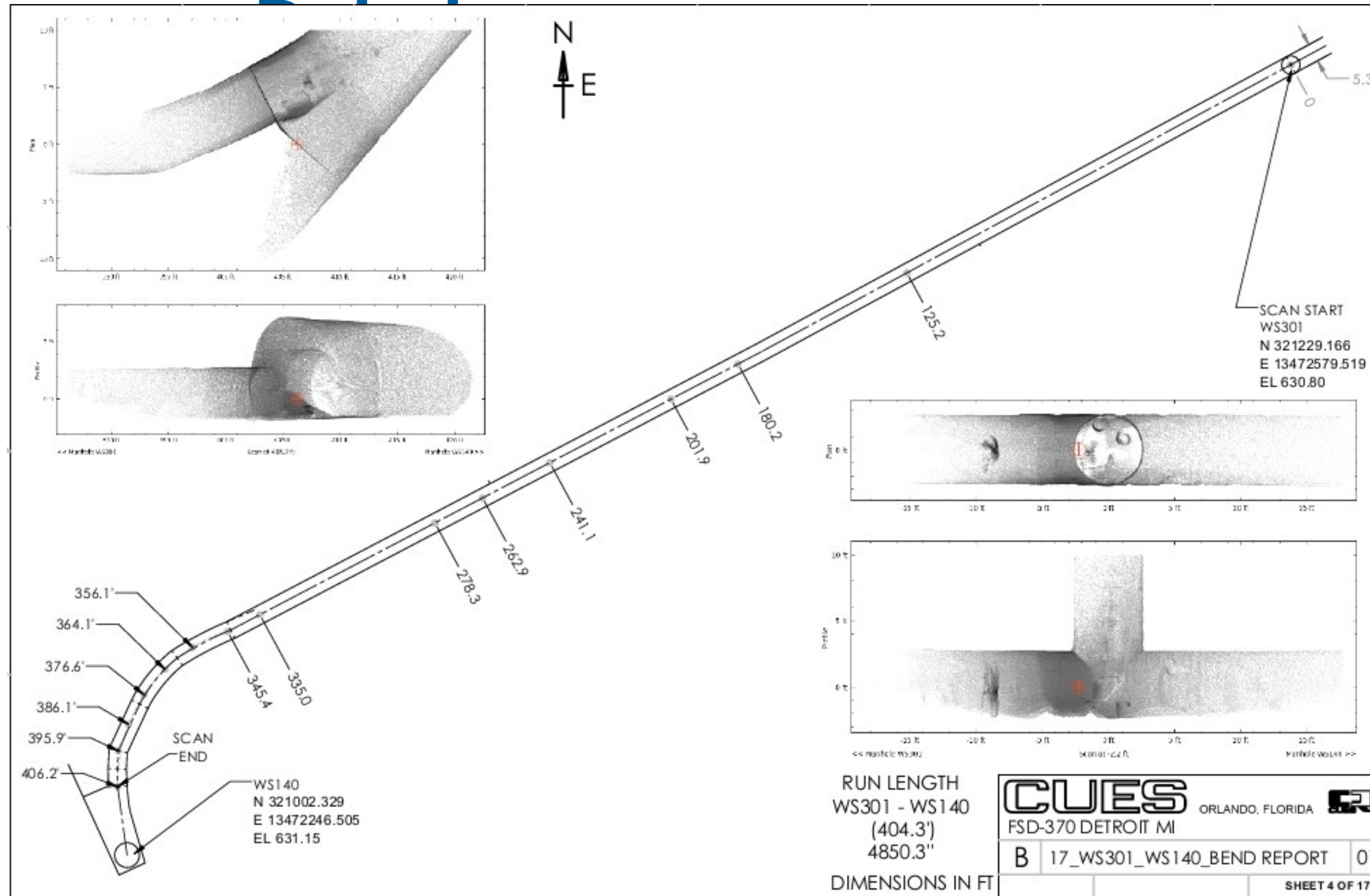

Detroit, MI – Woodward

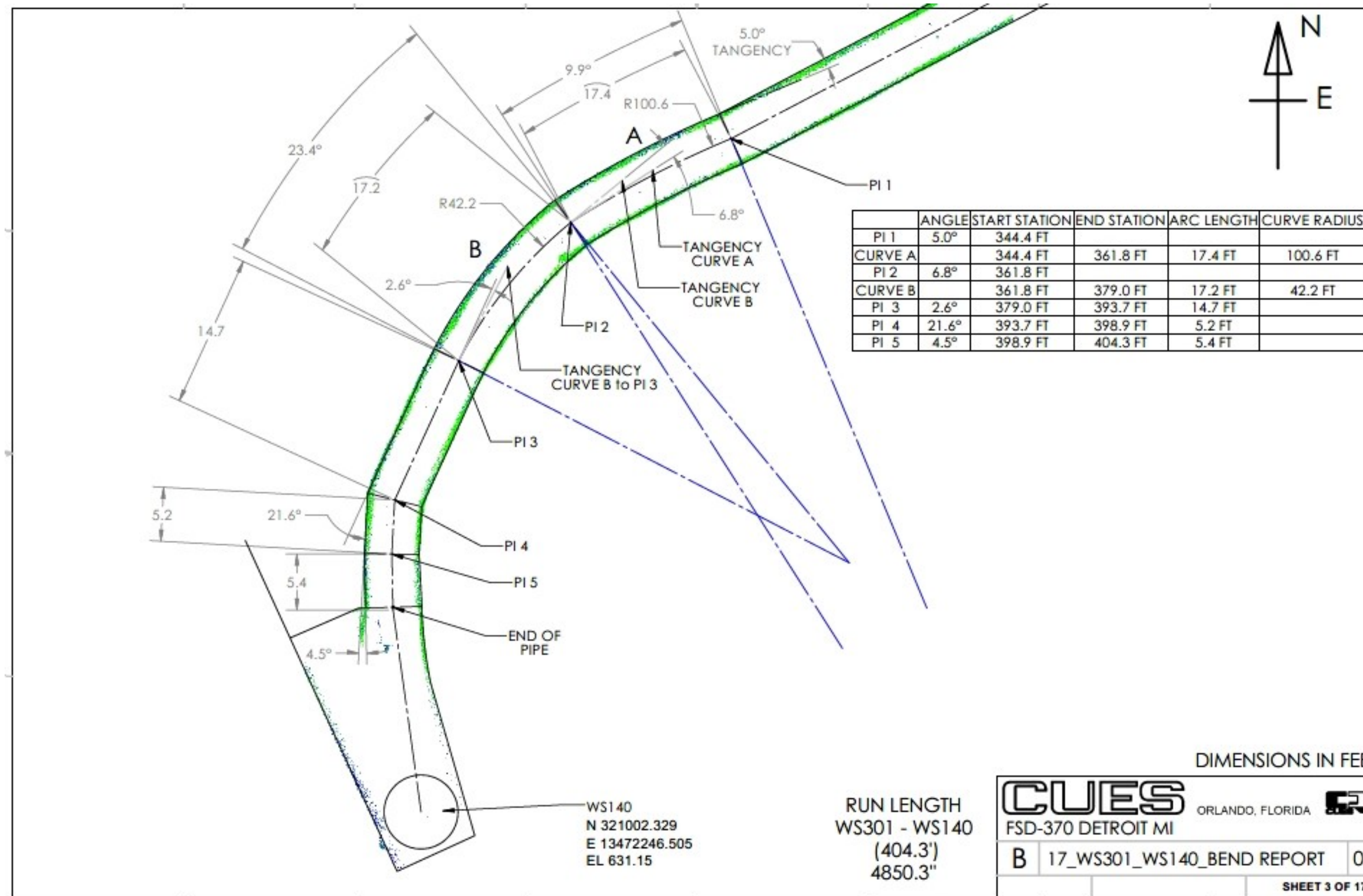

Detroit, MI – Woodward Rehab

Woodward Rehab

Size & Bend Analysis &

Geo-location

EGG SHAPED PIPE

FIELD WORK - SEPT 2022

What are the angles of the bends?
 What stick lengths will pass through the bends?

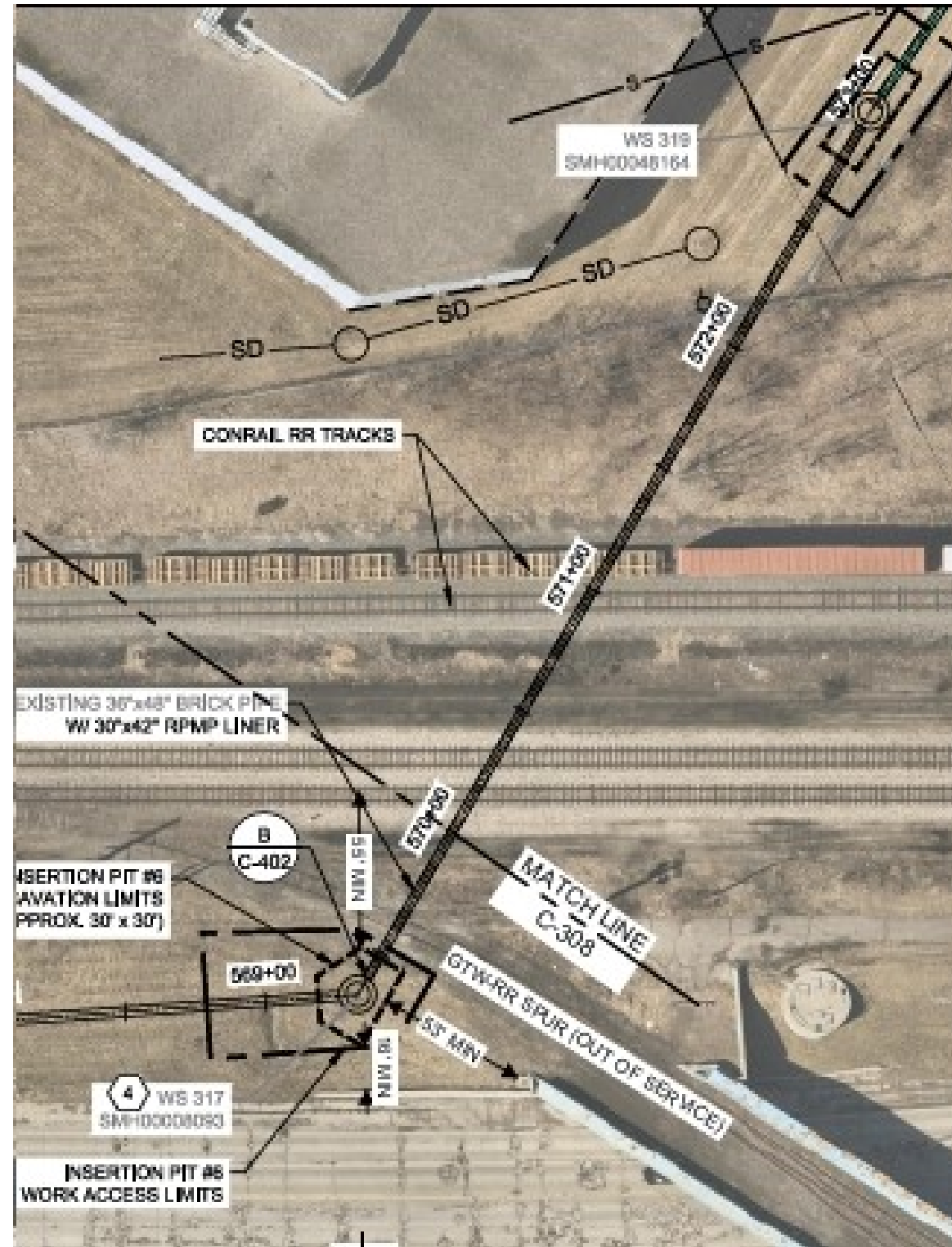

Detroit, MI – Woodward Rehab

CIRC - WS317 TO WS319

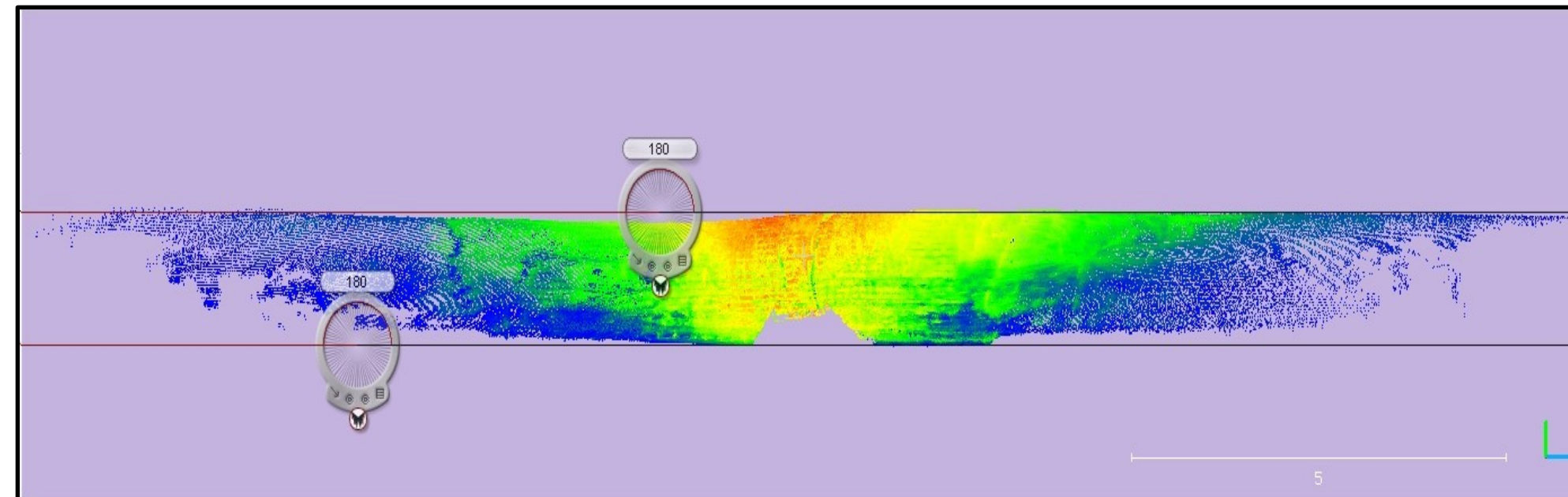
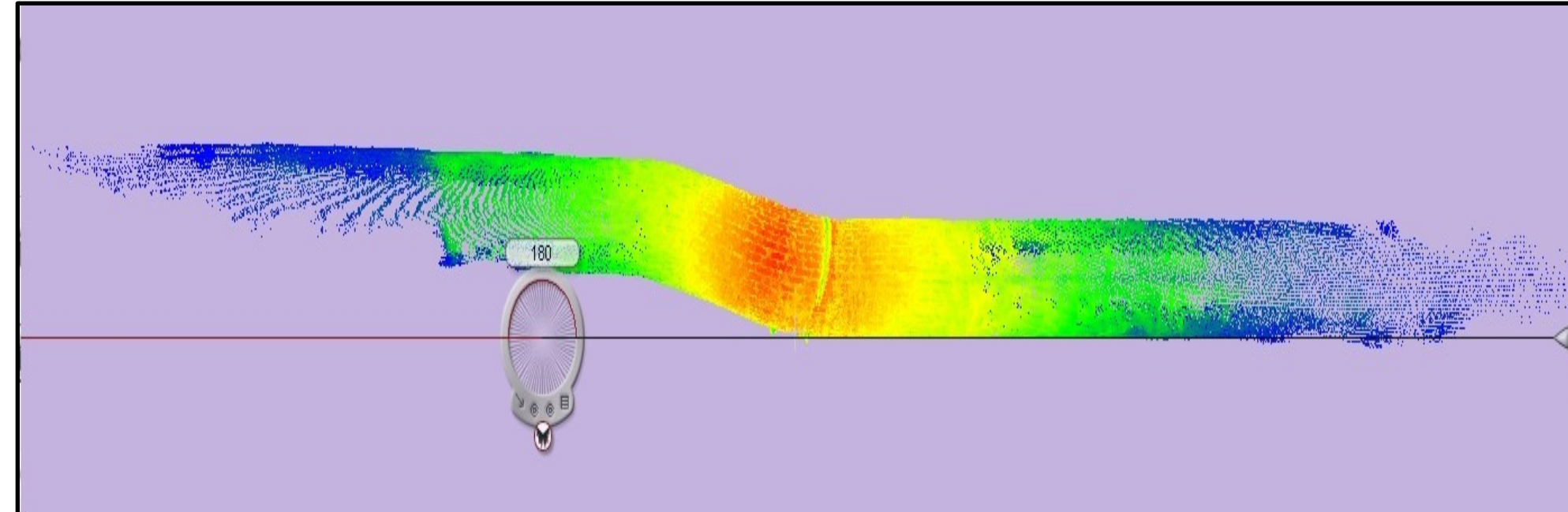

Detroit, MI - Woodward

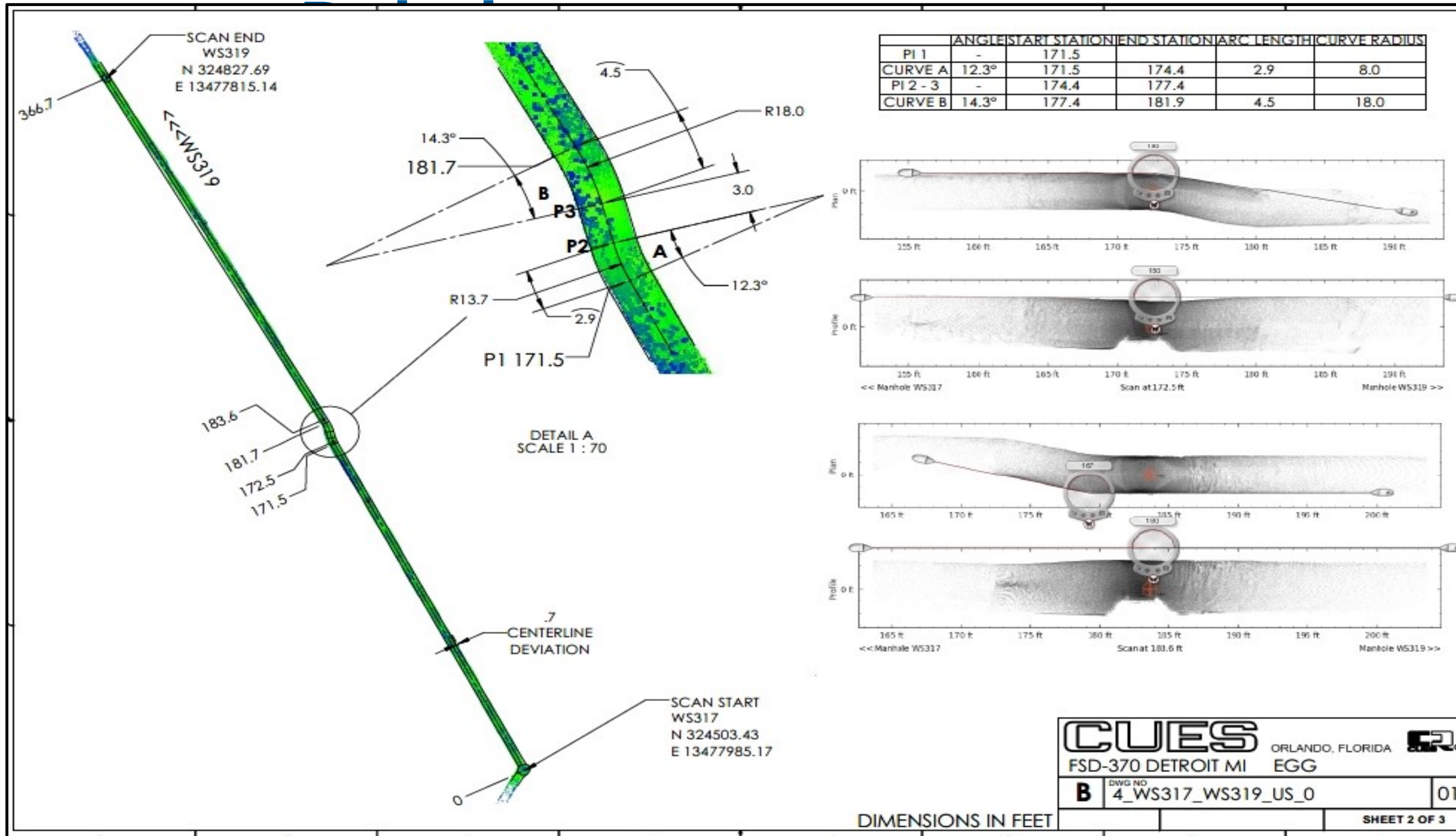

Detroit, MI – Woodward

In summary, the 3D LIDAR inspection and virtual mandrel analysis for RUN #4, indicate the approximate real shape of the brick egg pipe is as shown in Figure 23 below. Furthermore, the proposed Shape No. 2 NC Carrier Pipe may be too large for the host pipe. Areas of minimum width and height of concern for slip lining have been investigated and understood. If another NC Carrier Shape is defined, we can insert that new shape into the cross sectioning tool and show the new annulus space that results.

CROSS SECTION ANALYSIS

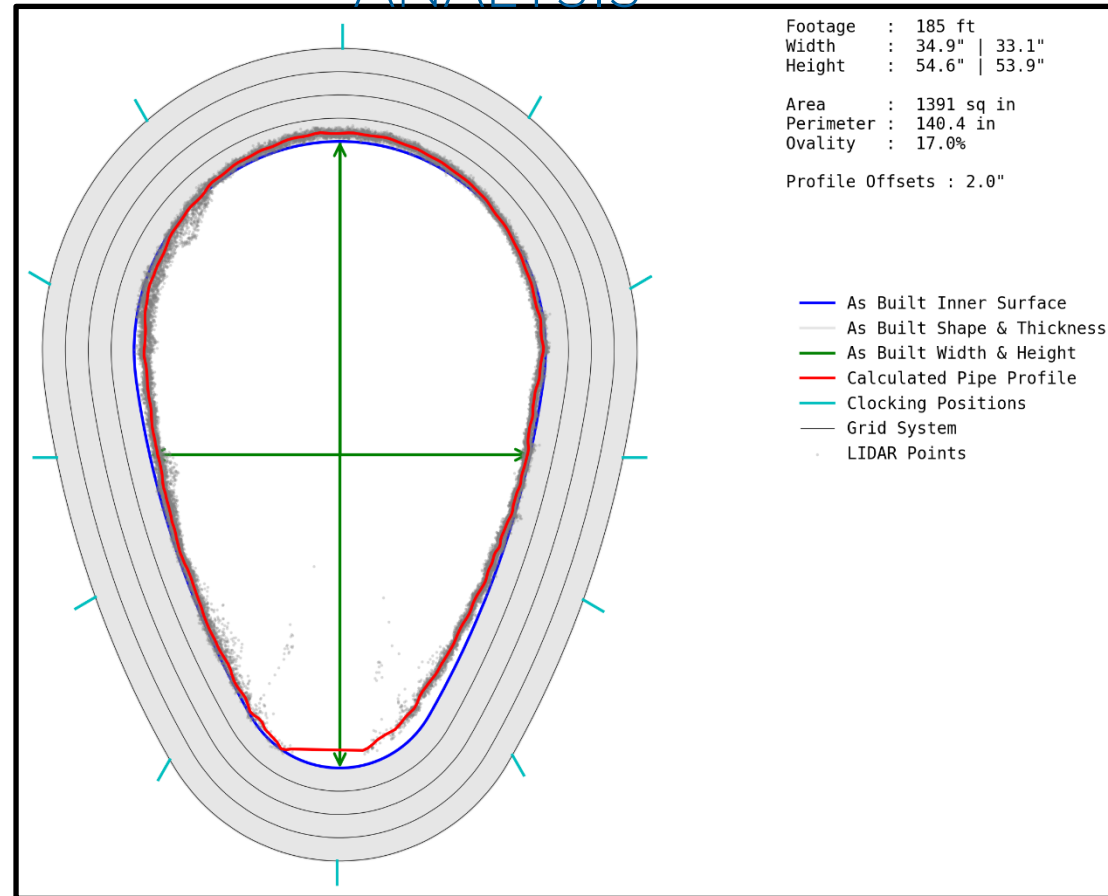

LIDAR vs. AS-BUILT SHAPE

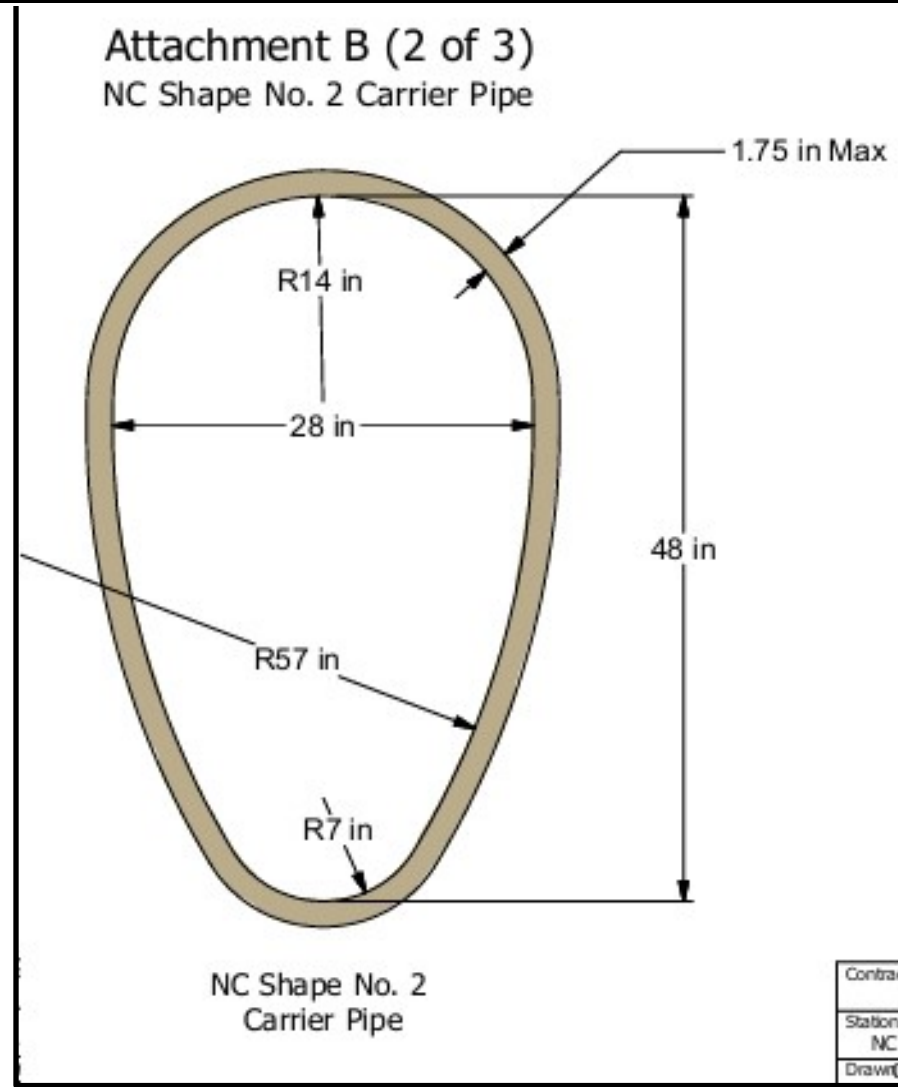

PROPOSED CARRIER PIPE (LINER)

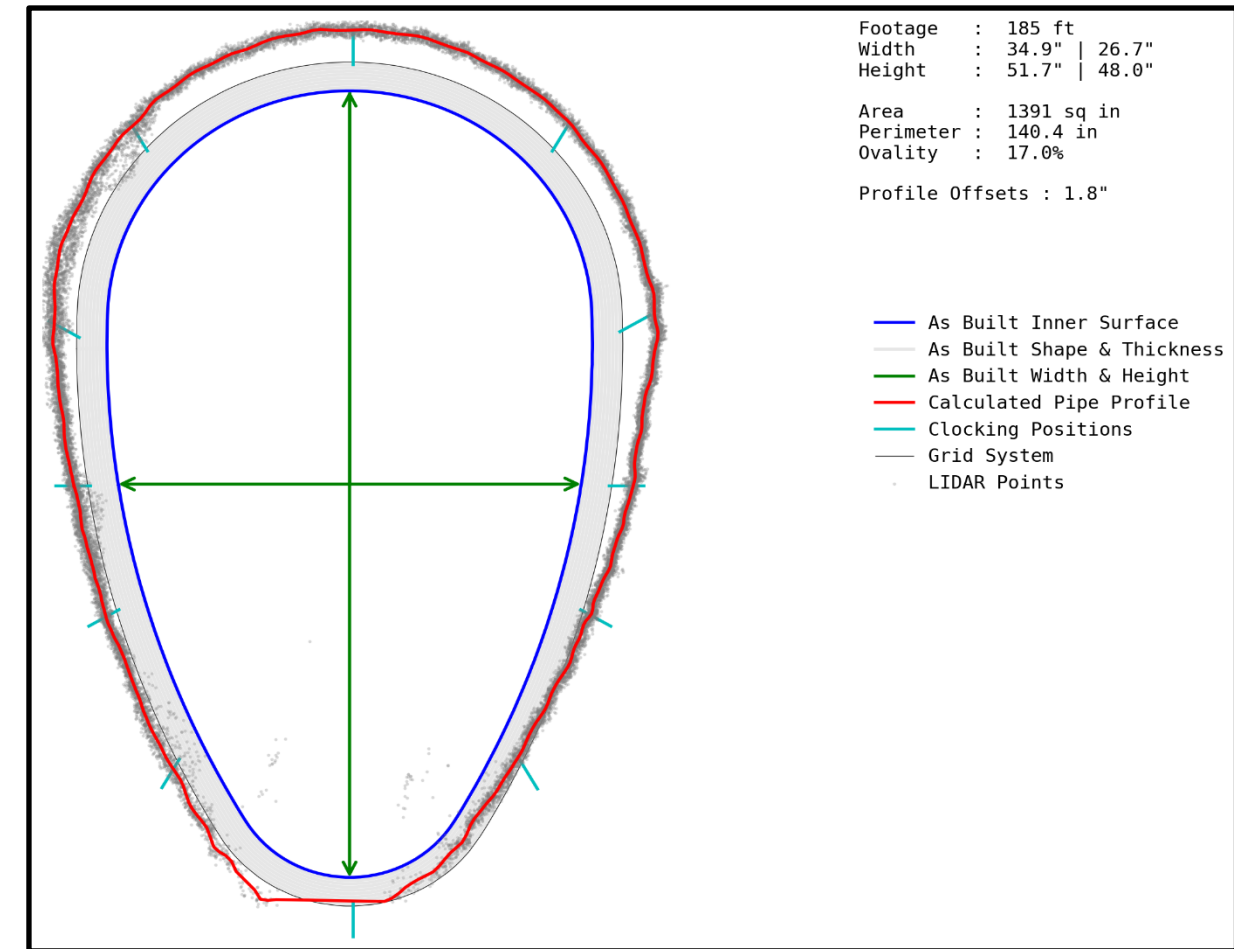

CARRIER vs. LIDAR

Detroit, MI – Woodward Rehab

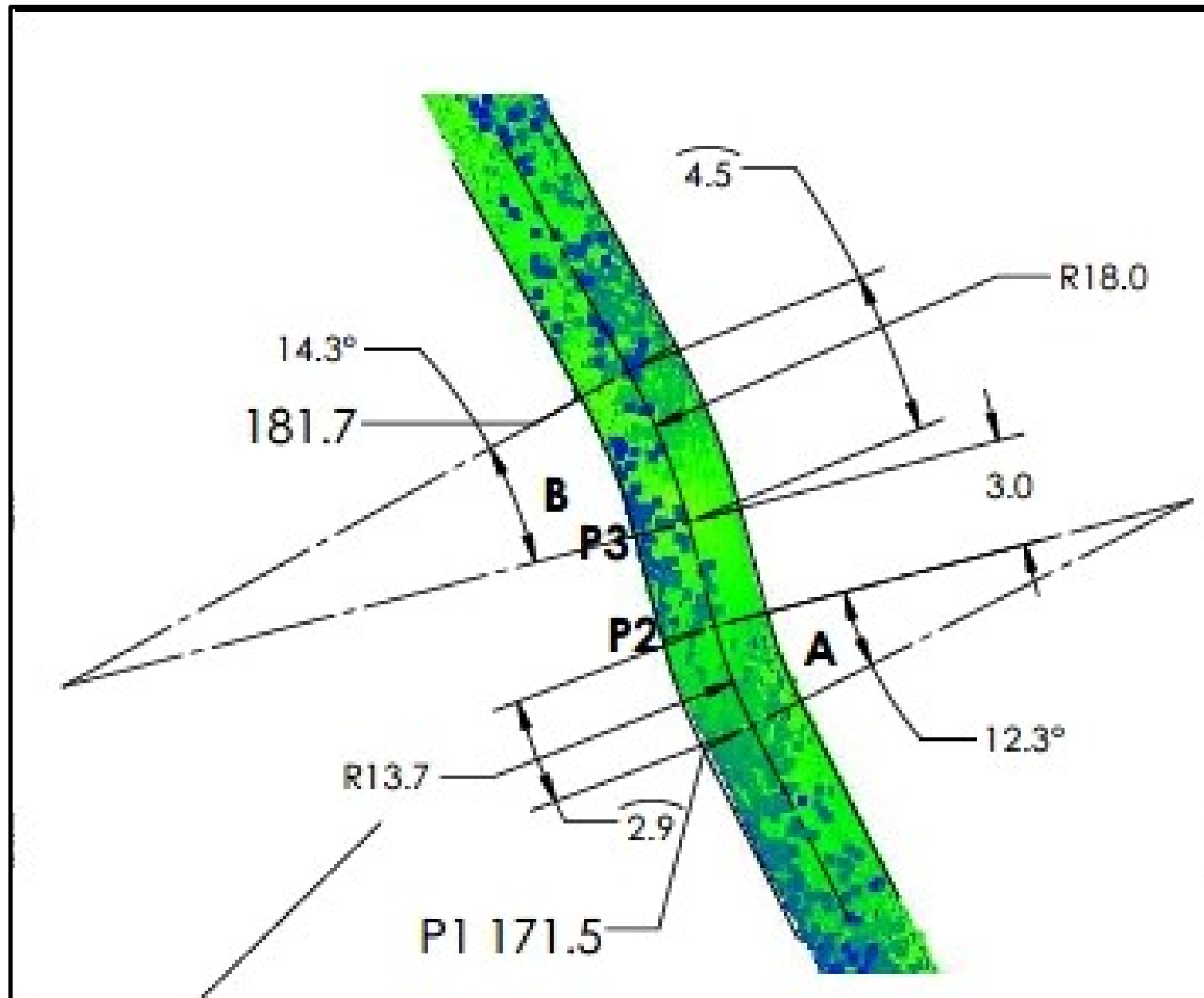

VIRTUAL MANDREL ANALYSIS

MAX STICK LENGTH THROUGH RUN #4 BENDS = 3 FT
 MAX STICK LENGTH FOR RUN #4 STRAIGHTS = 8 FT

Salt Lake, UT

Influent Structure Rehab Size and Bend Analysis

What is the miter angle in 90" pipe?
 Wait is the bend radius of the 54" and 84" interceptors?
 What is the size or height of the influent channel?

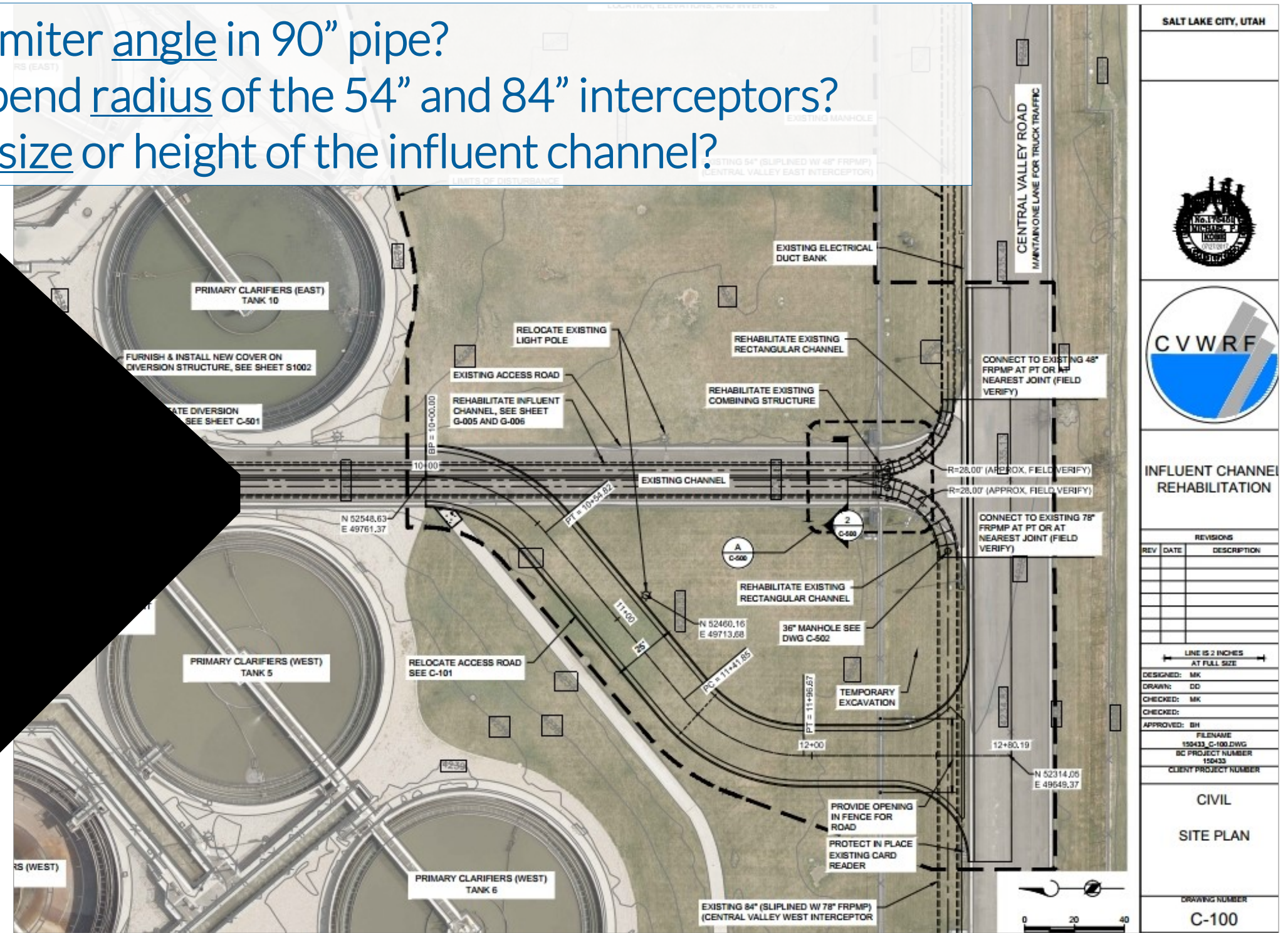
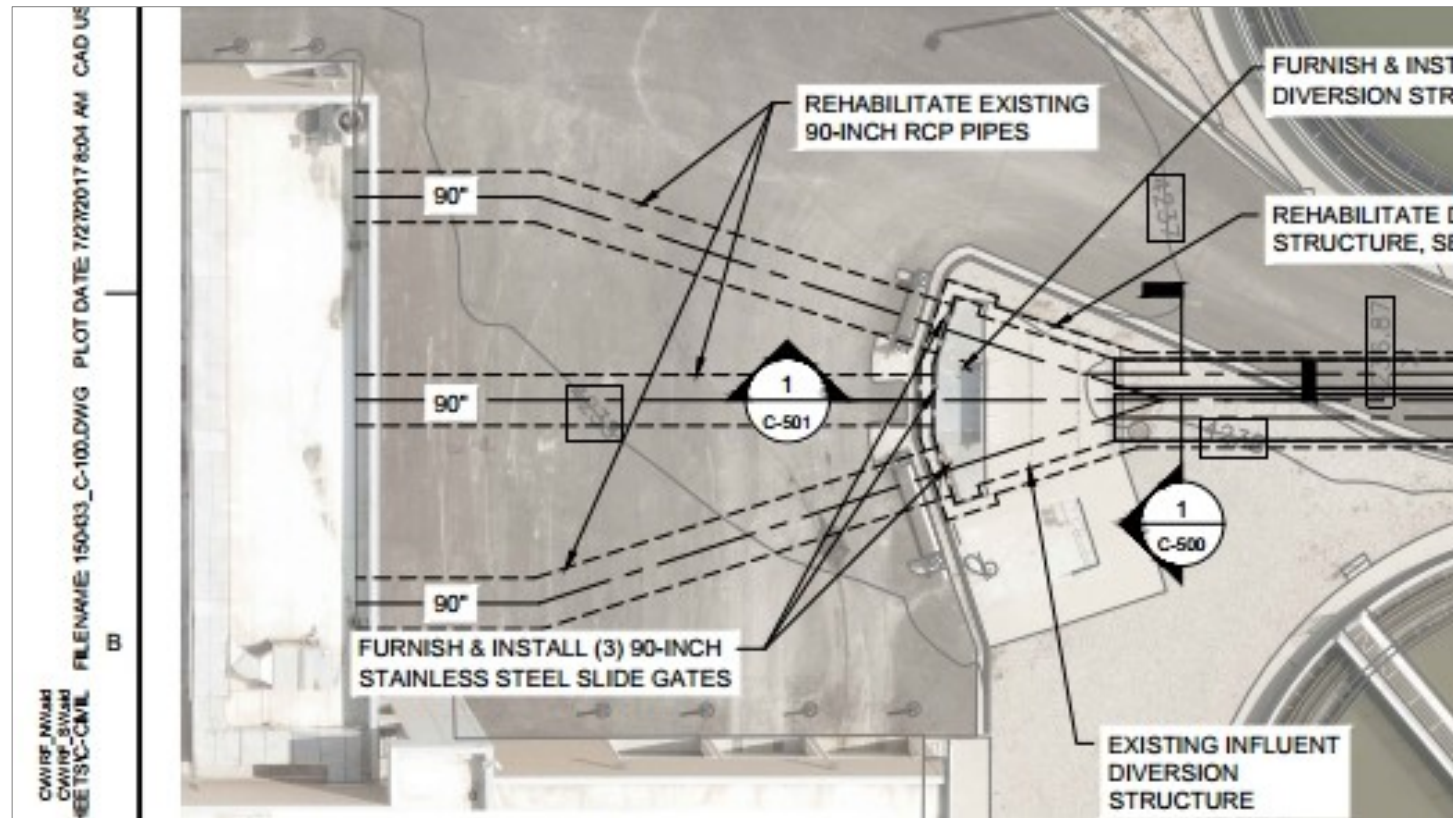

SALT LAKE CITY, UTAH

CVWRF

INFLUENT CHANNEL REHABILITATION

REVISIONS	
REV	DESCRIPTION

LINE IS 2 INCHES AT FULL SIZE

DESIGNED: MK
 DRAWN: DD
 CHECKED: MK
 APPROVED: BH

FILENAME: 150433_C-100.DWG
 BC PROJECT NUMBER: 150433
 CLIENT PROJECT NUMBER:

CIVIL
 SITE PLAN

DRAWING NUMBER: C-100

Salt Lake, UT (cont.)

Influent Structure Rehab

SMM Setup

90" Diversion Pipe

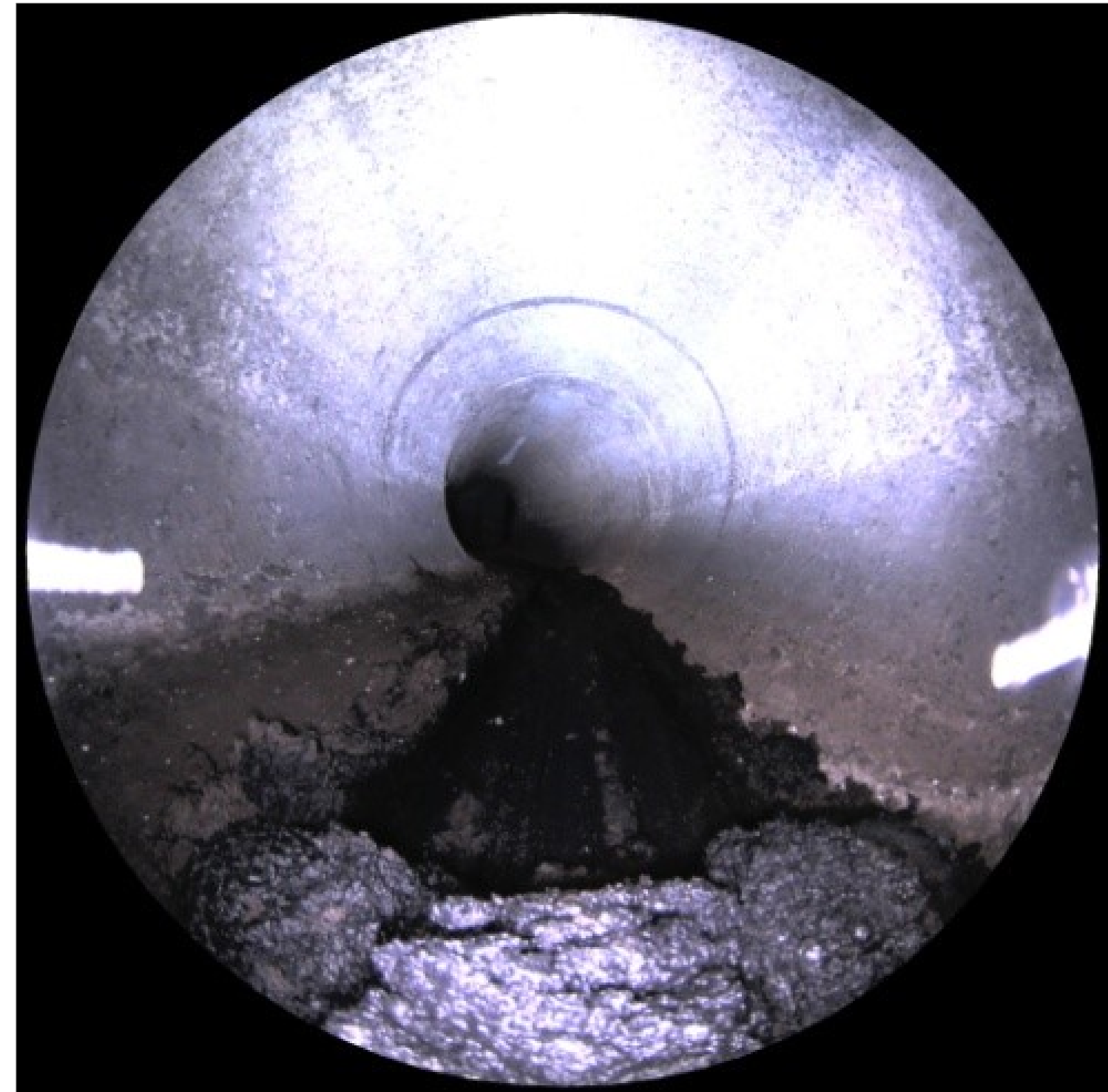
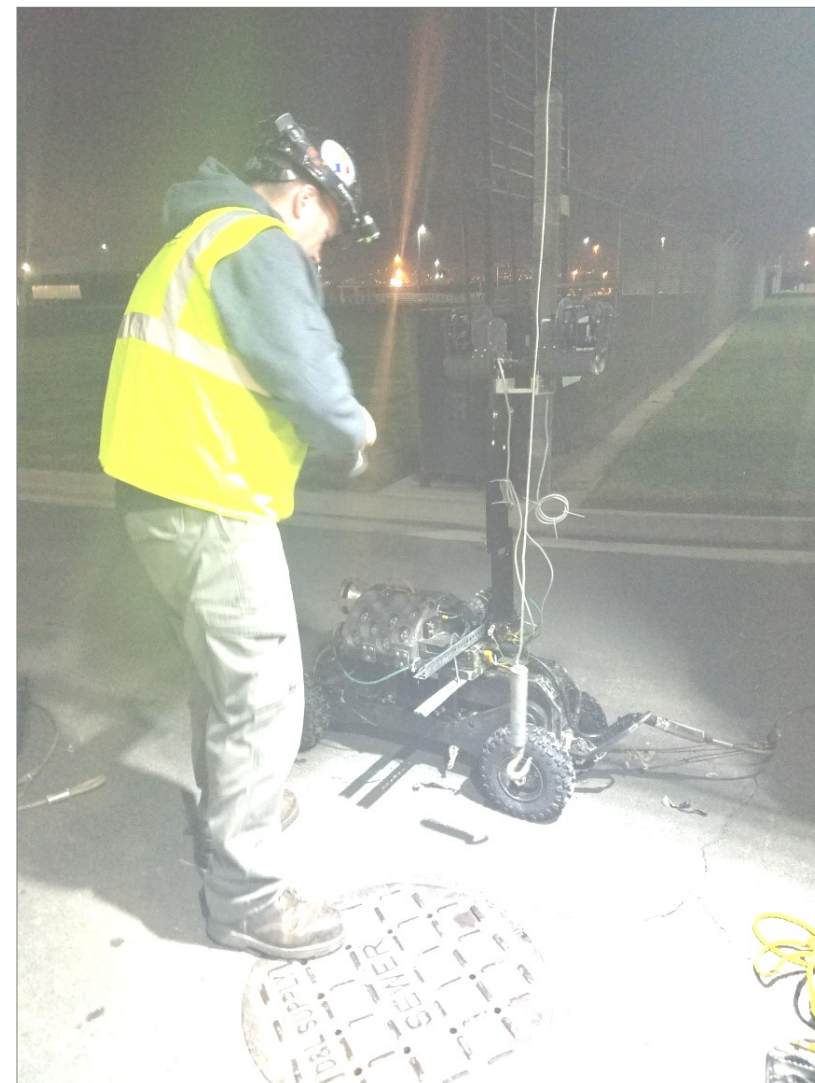

Salt Lake, UT (cont.)

Influent Structure Rehab 90" Diversion Pipe CAD Drawing

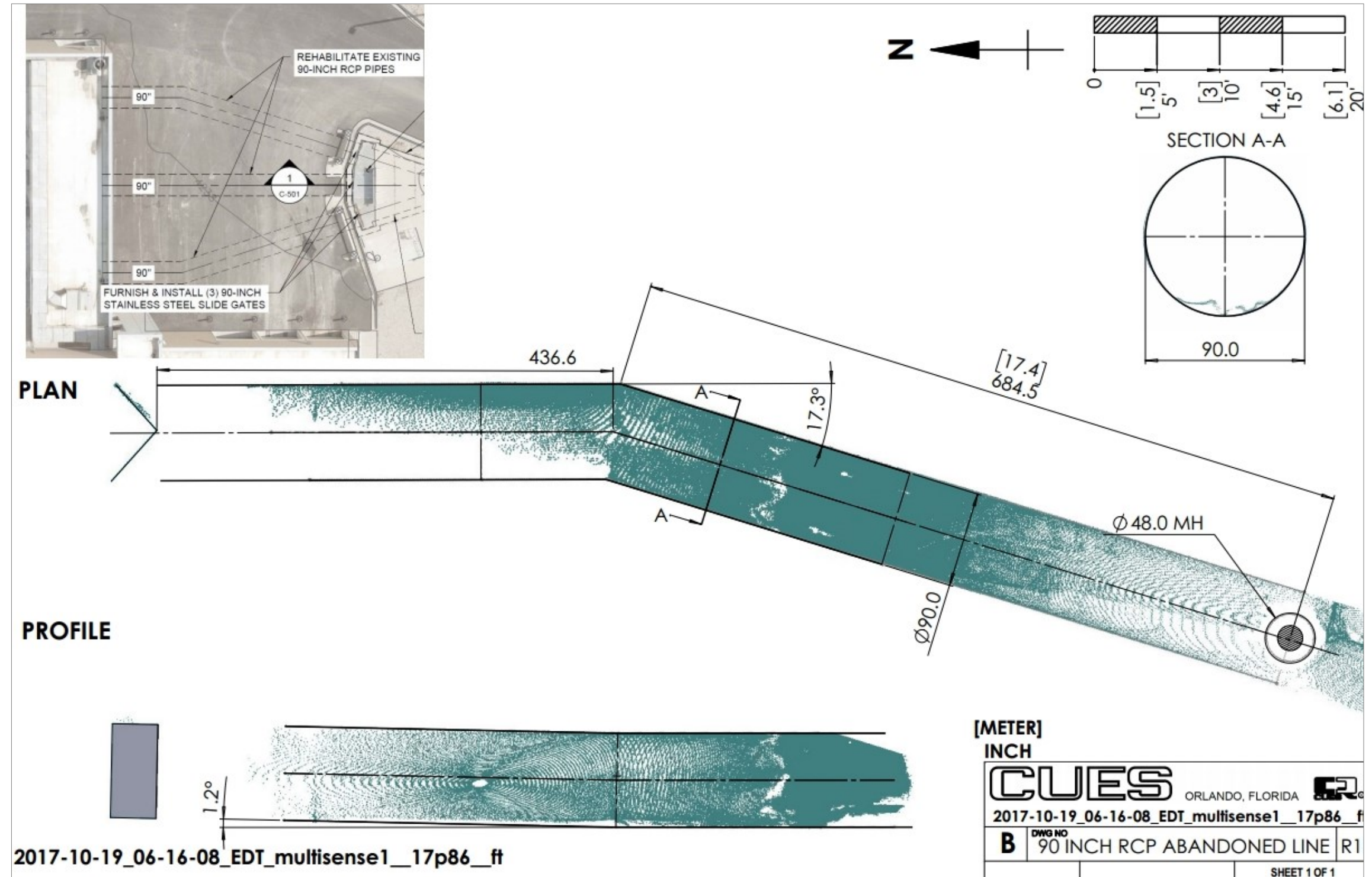

Salt Lake, UT (cont.)

Influent Structure Rehab Custom Liner Installation



Salt Lake, UT (cont.)

Influent Structure Rehab
 Influent Channel Size?
 Does the height change?

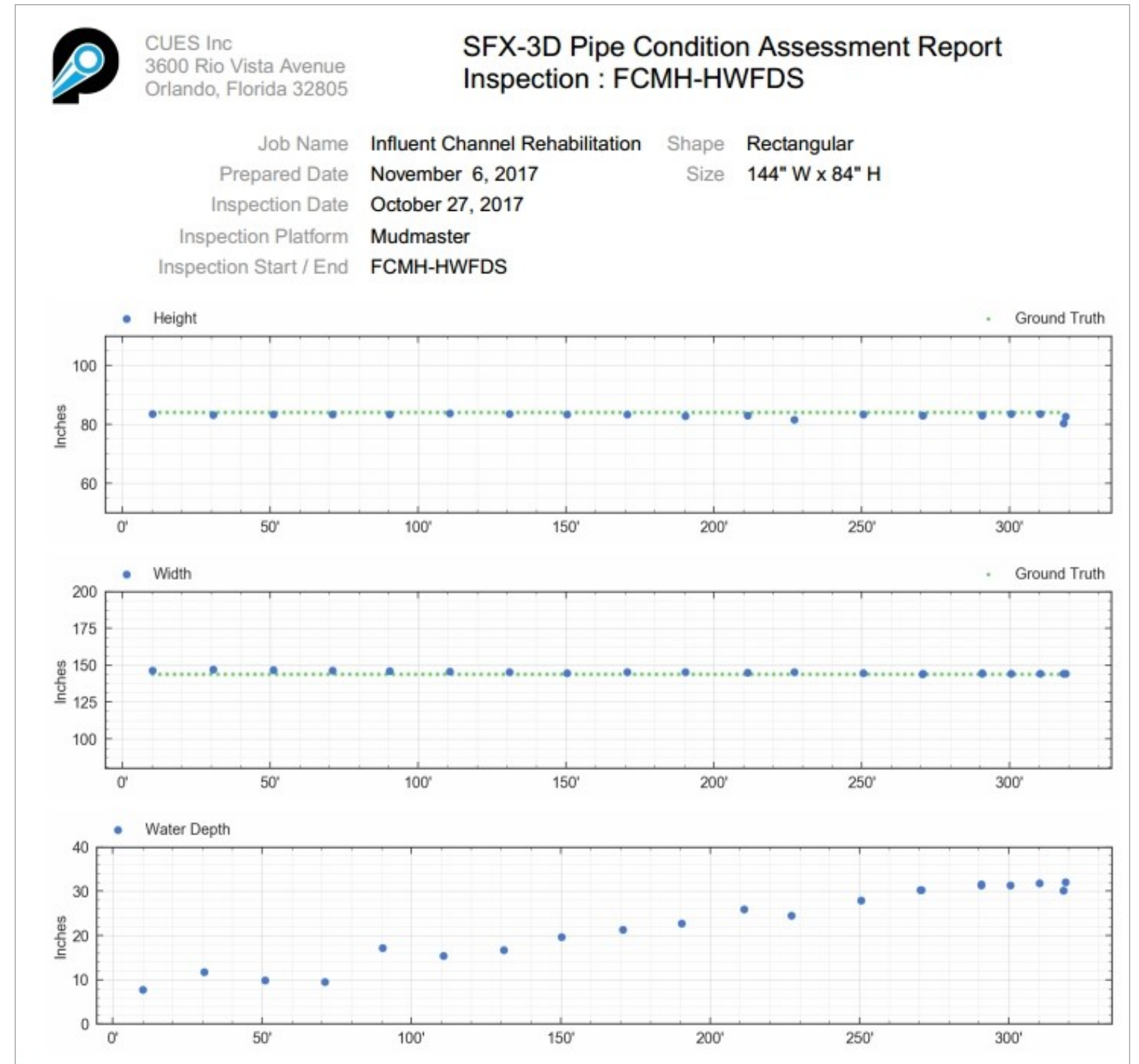
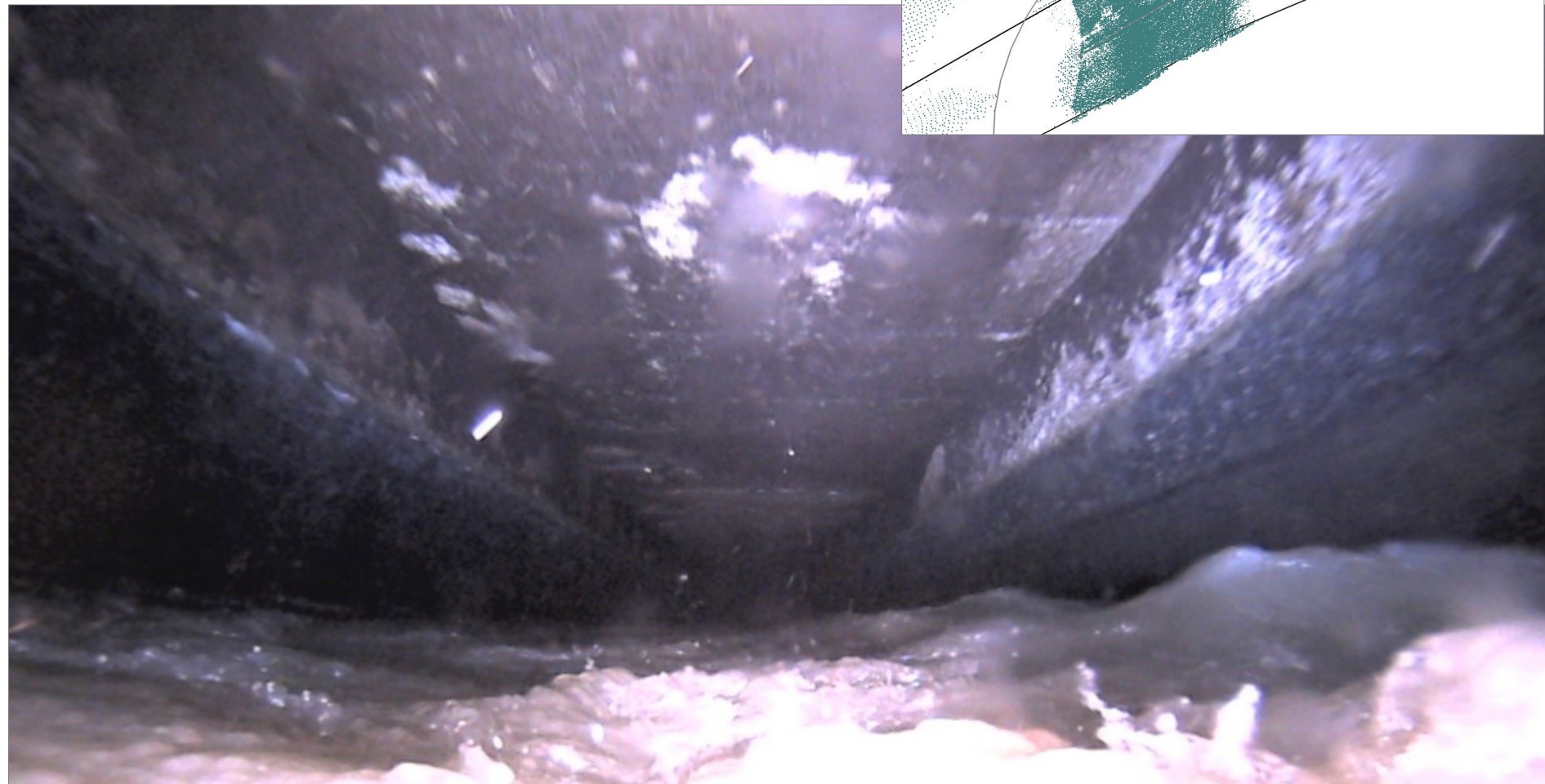
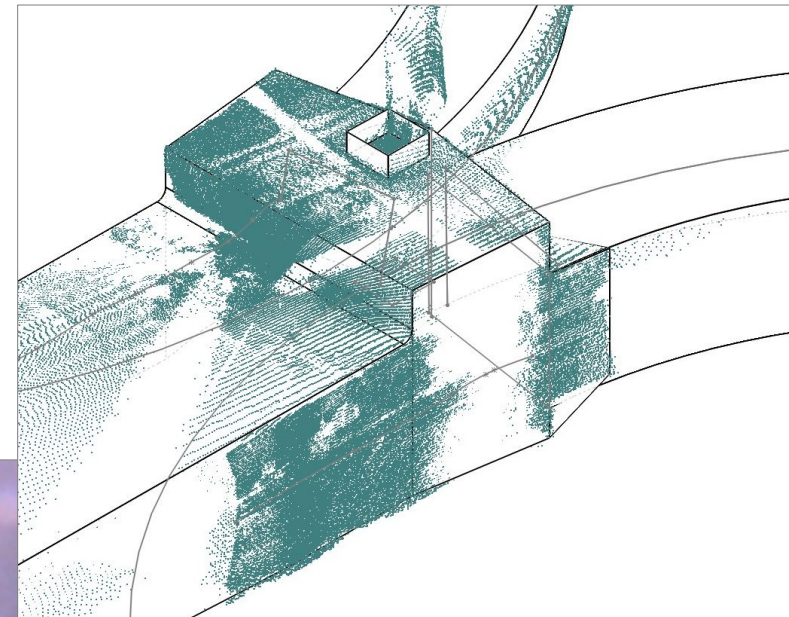

Salt Lake, UT (cont.)

Influent Structure Rehab Combining Structure – Radii?

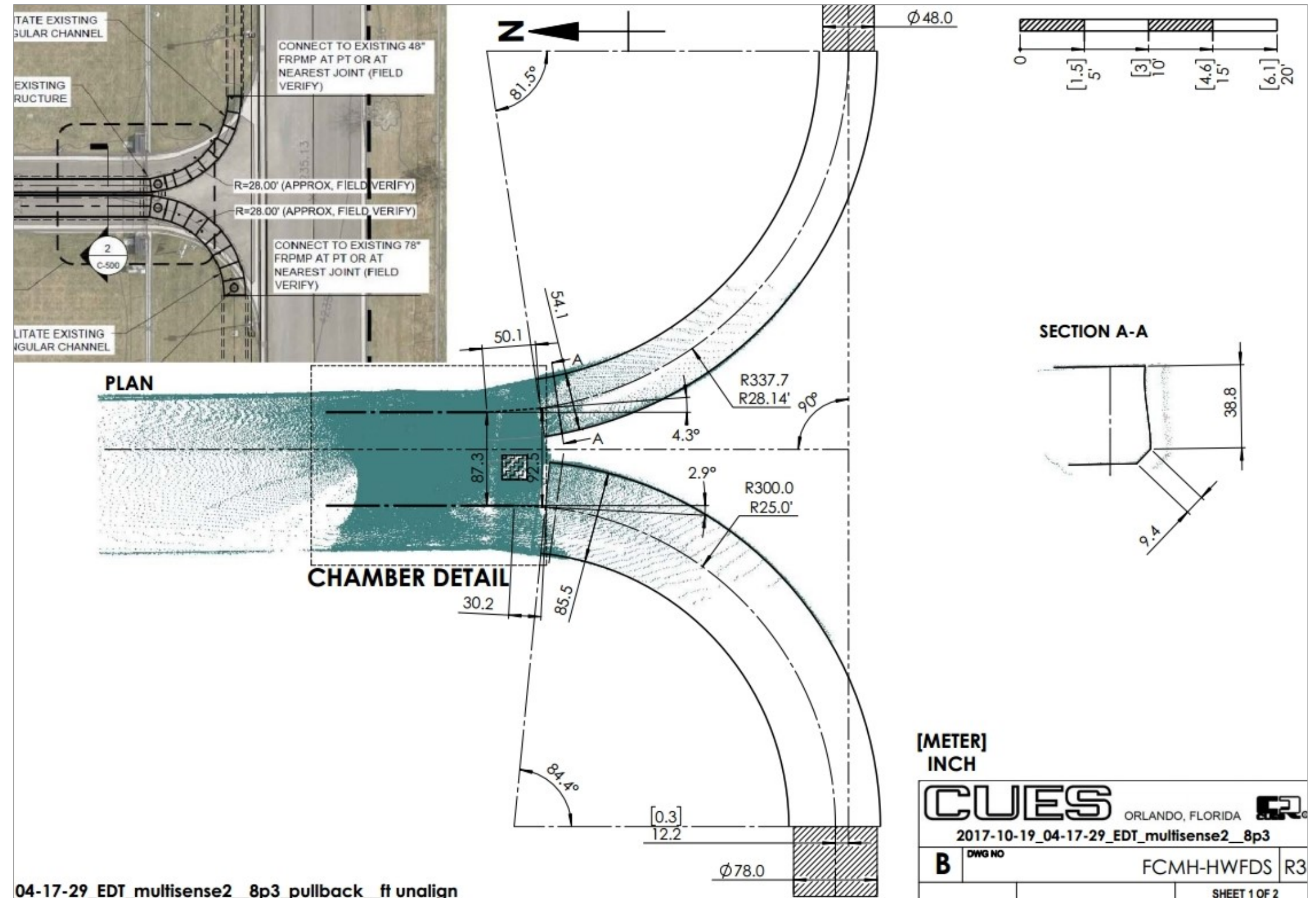
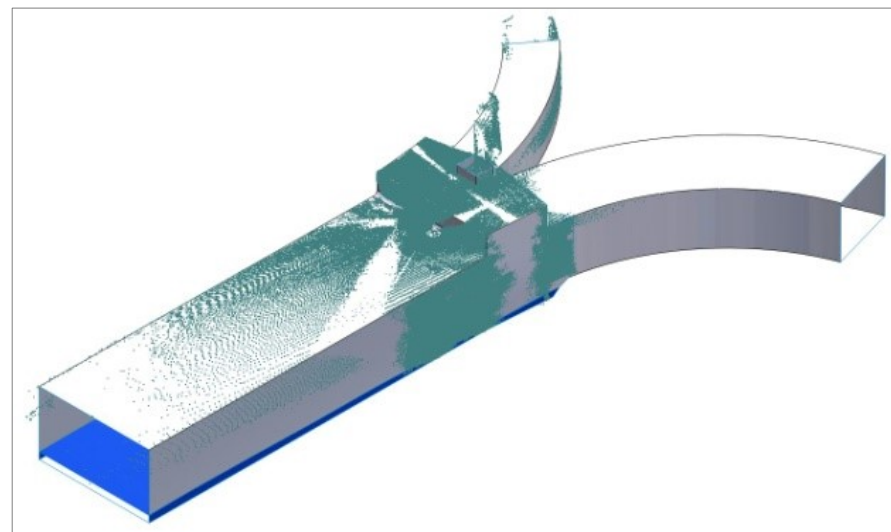
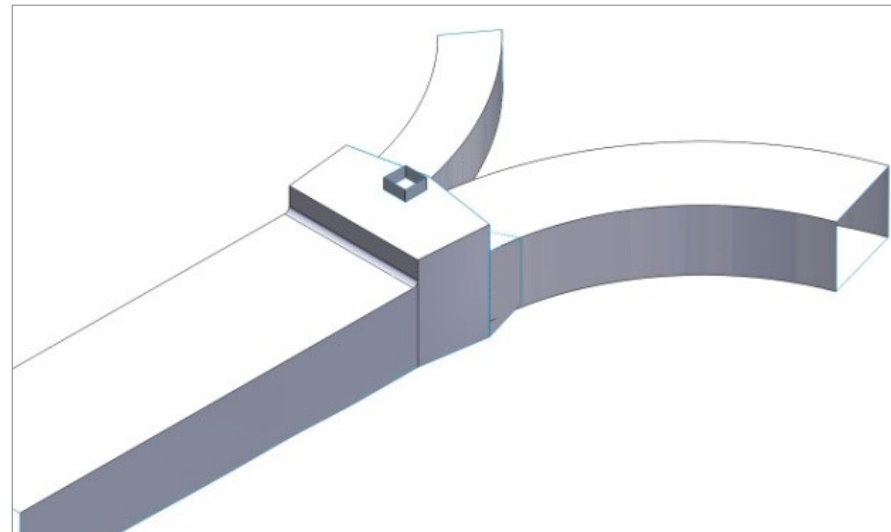

Salt Lake, UT (cont.)

Influent Structure Rehab Chamber Detail

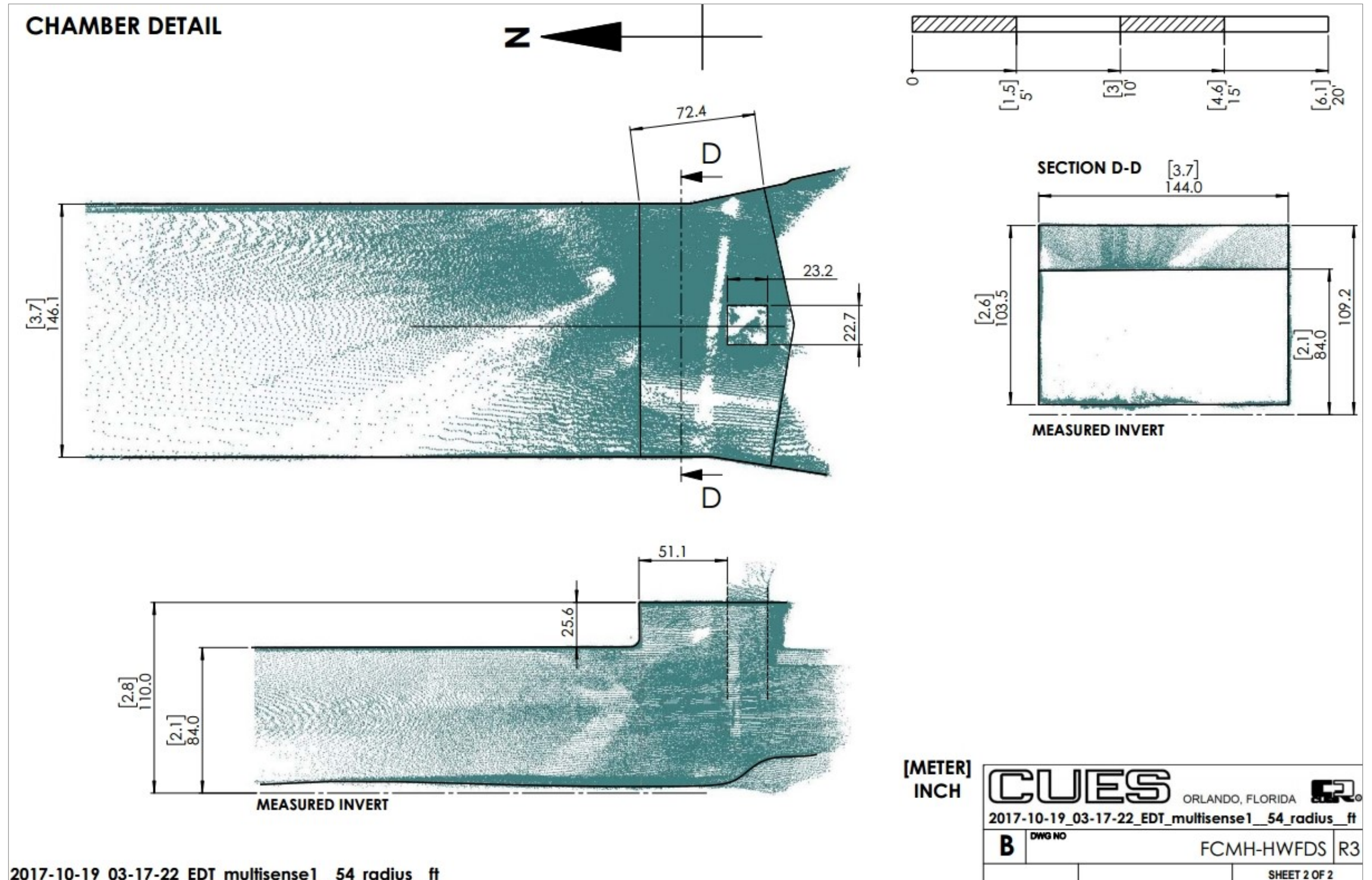
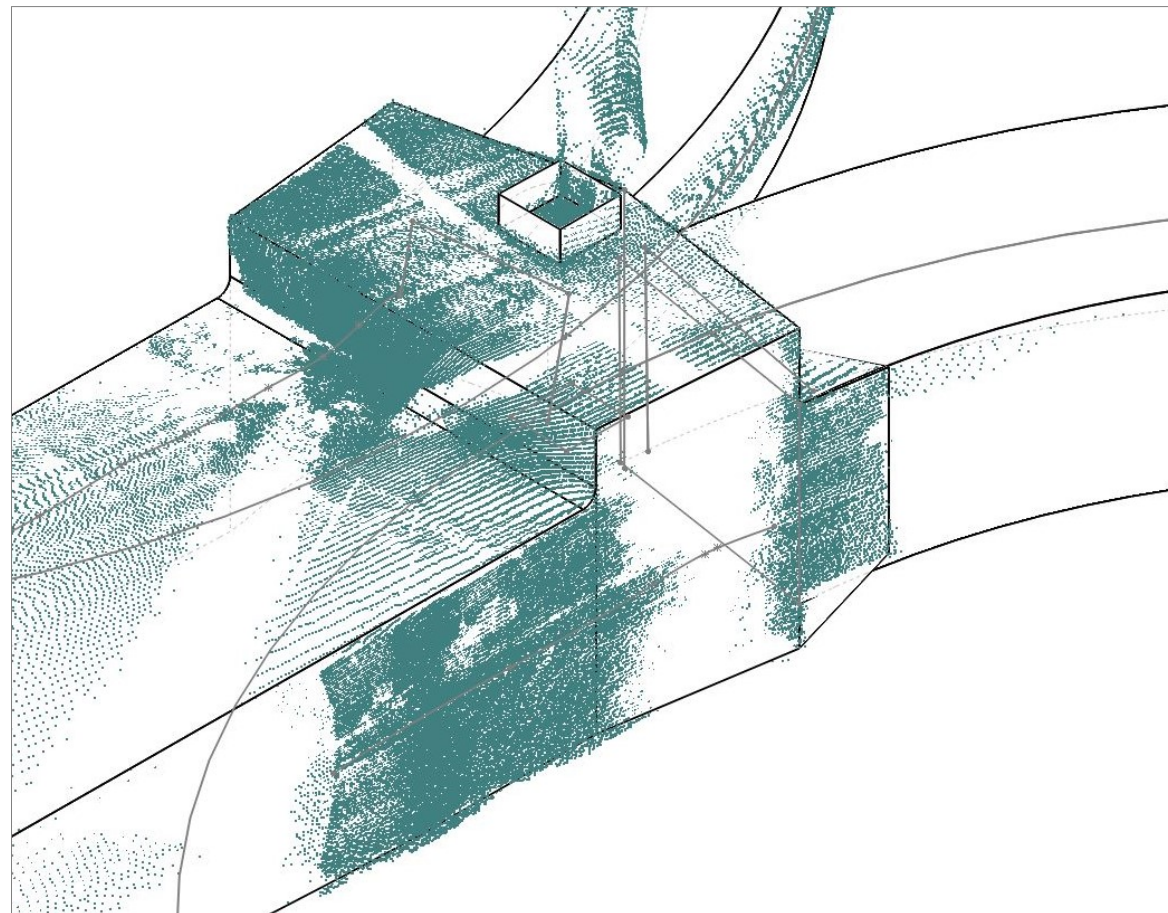

Edmonton Alberta, CA

Drill and Rehab Project

Geo Location & Cross Section Report

- What is smallest cross section of the E-W tunnel?
- Where should be dig our 10' diameter, 100 ft. deep rehab/maintenance shaft?

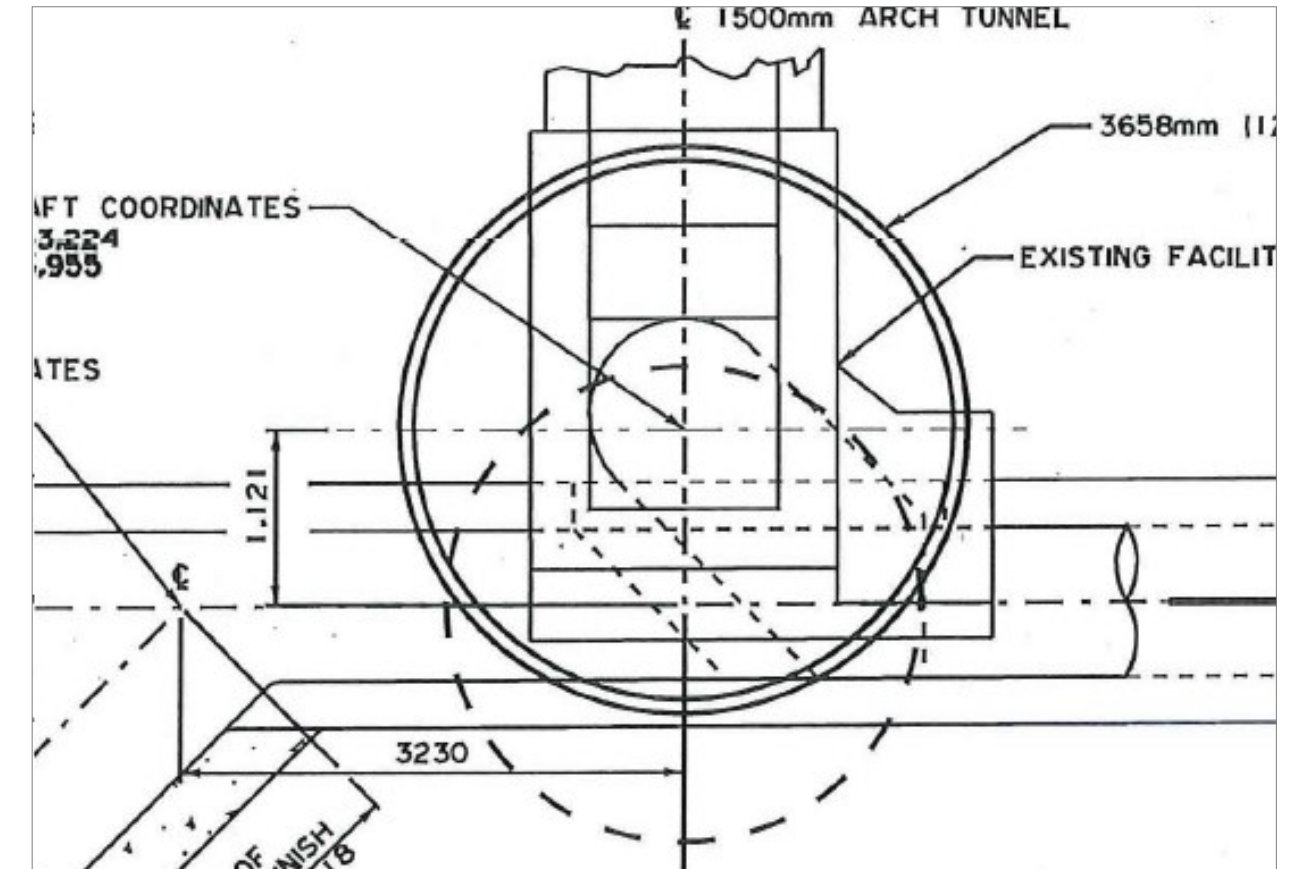
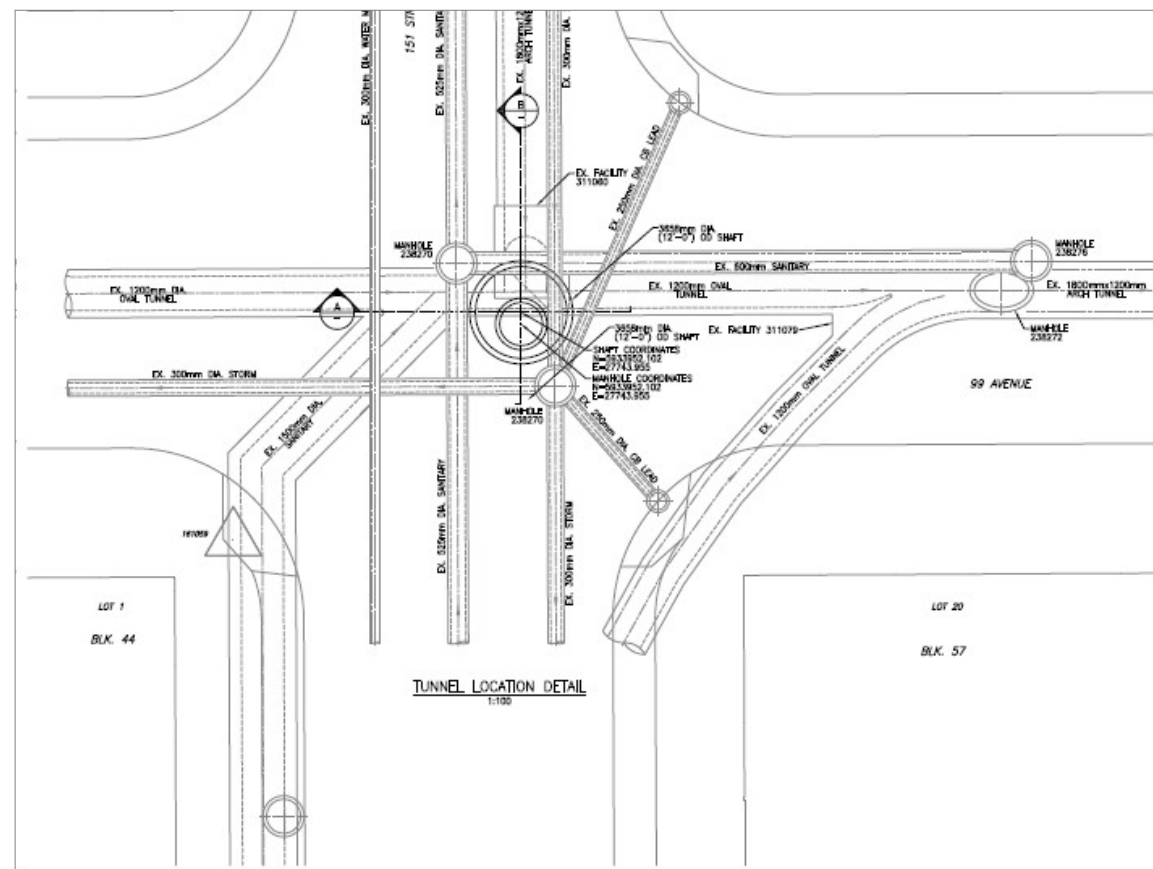

Edmonton Alberta, CA (cont.)

Drill and Rehab Project Deliverable - Cross Sections

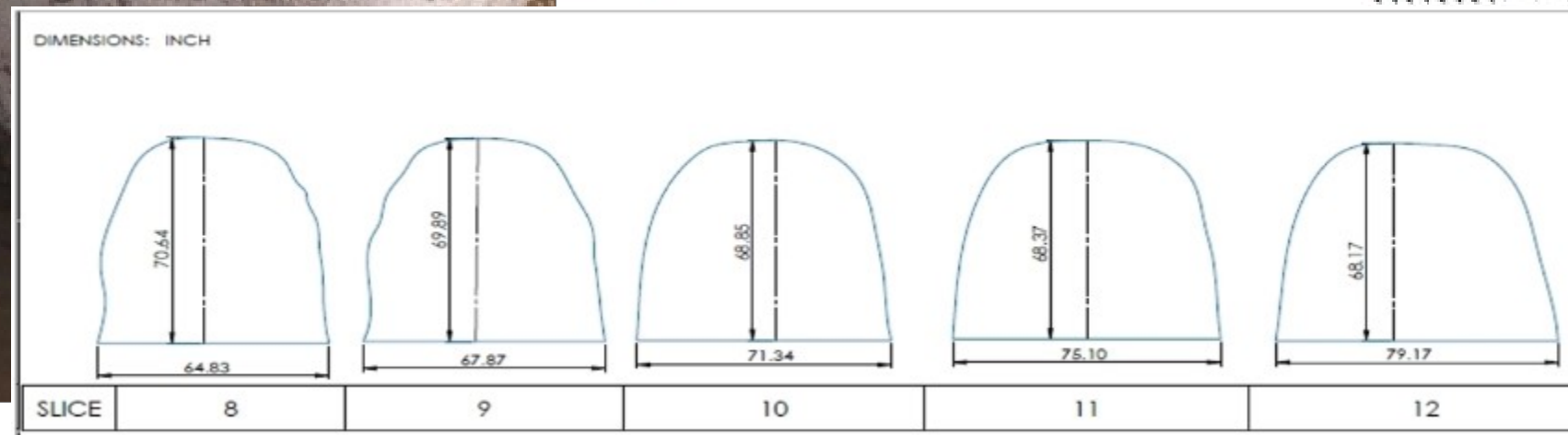
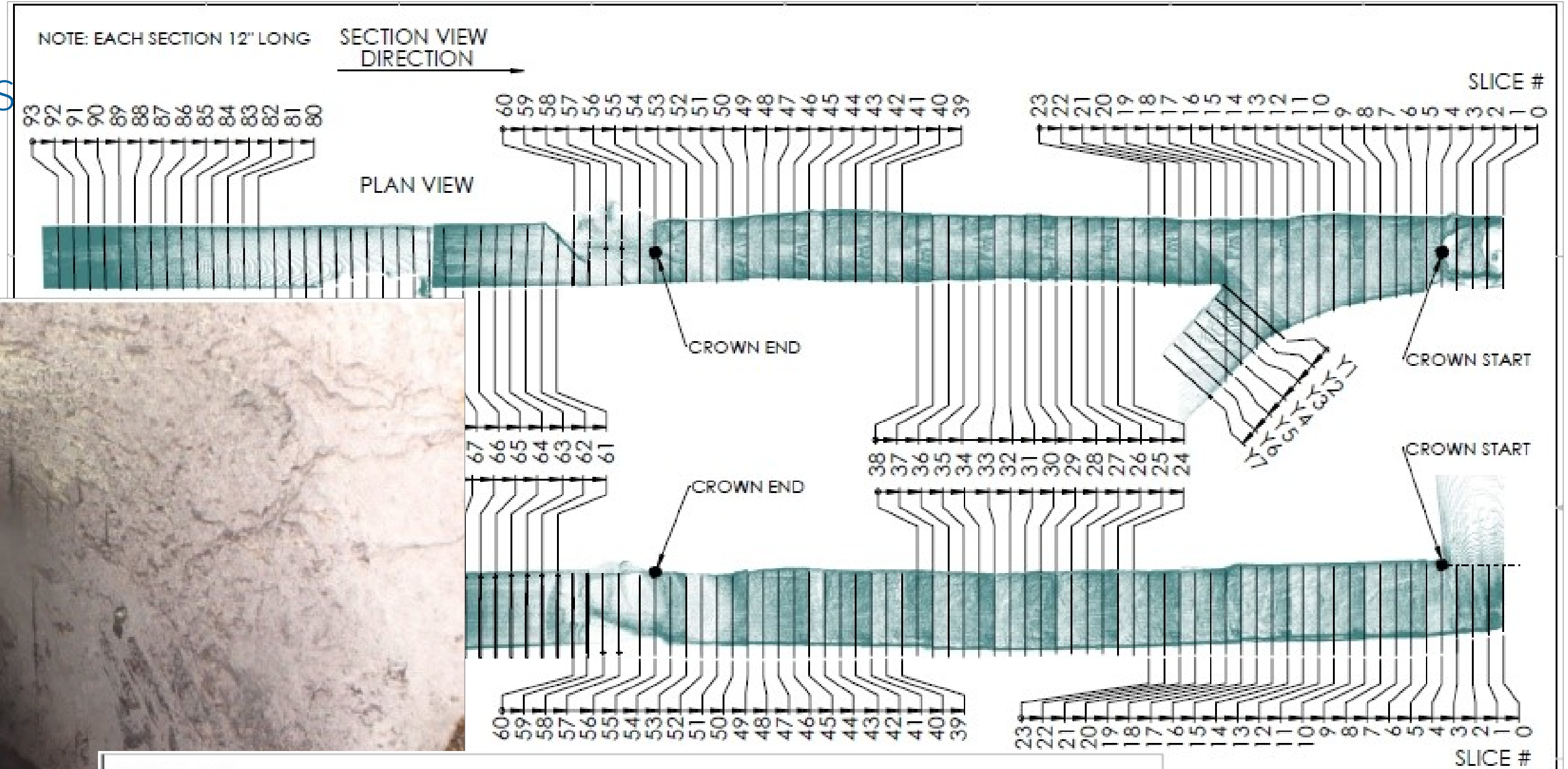

CUES ORLANDO, FLORIDA 

Cross Sections - Anytown USA

DWG NO: _____ REV: R1

SCALE: 1:3 WEIGHT: _____ SHEET 1 OF 22

Edmonton Alberta, CA (cont.)

Drill and Rehab Project

Deployment Into N-S Bypass Pipe
Scans At Bottom of 100' Deep MH

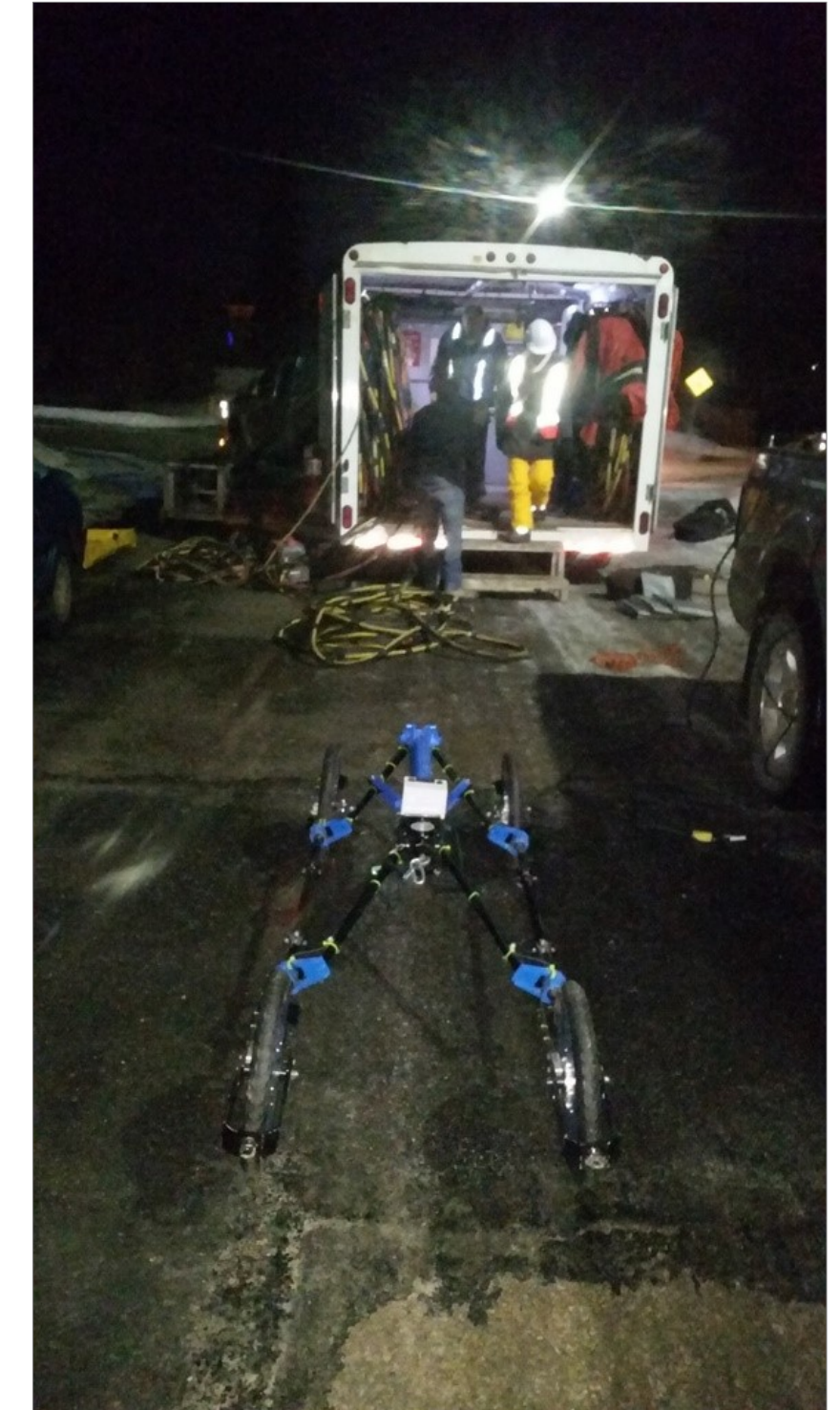
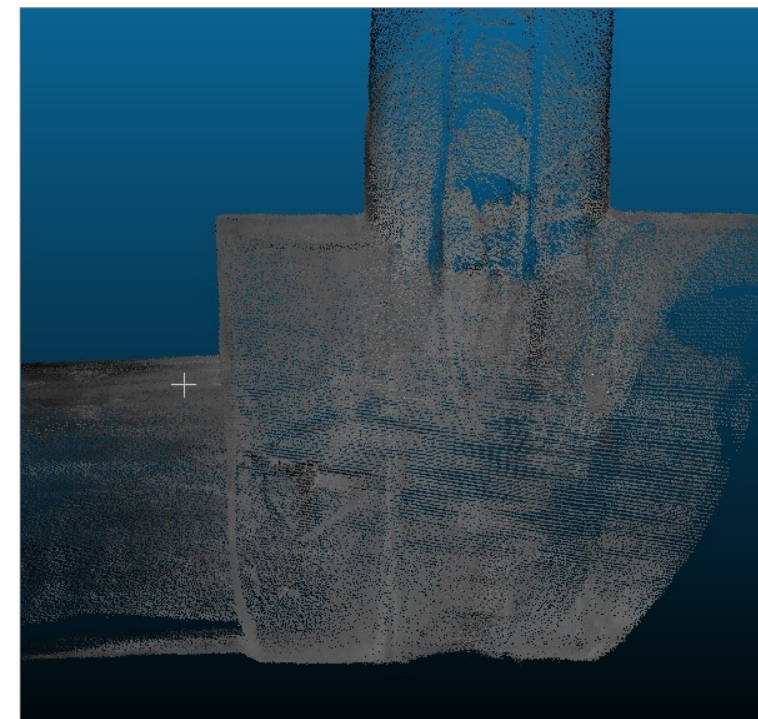
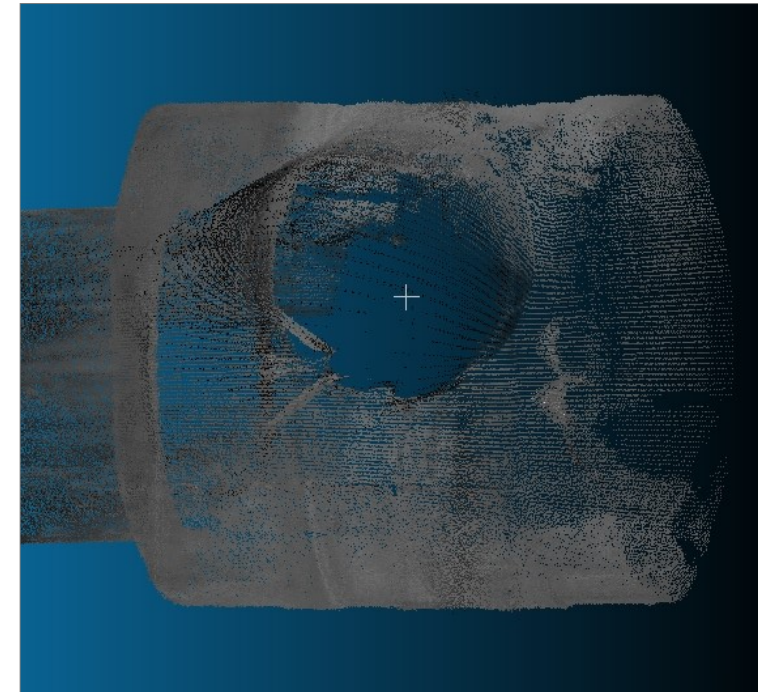
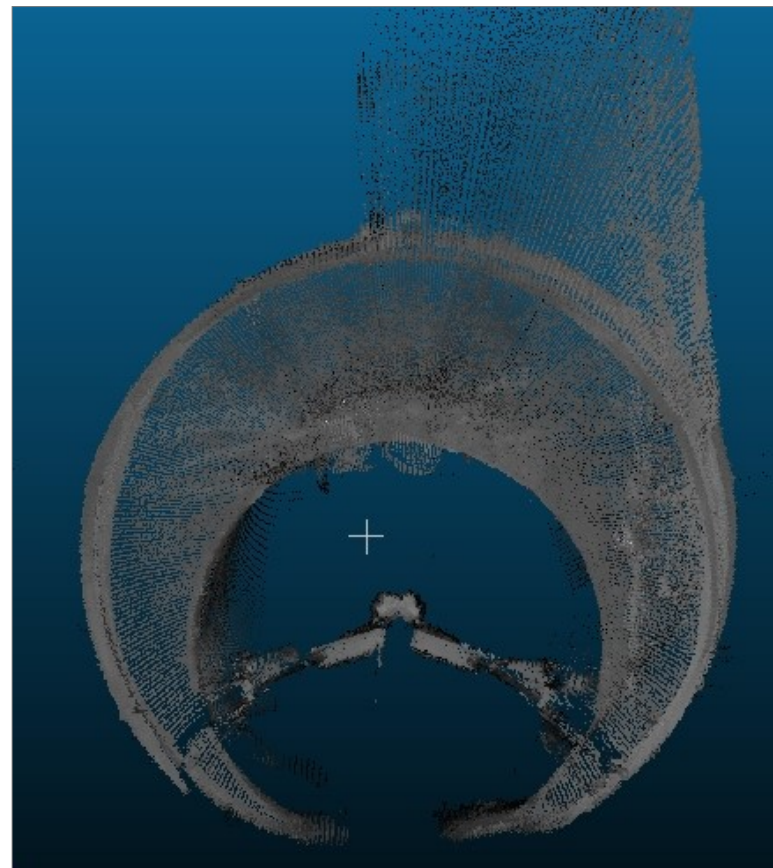

Edmonton Alberta, CA (cont.)

Drill and Rehab Project Offset MH

- Drop plumb line
- GPS coordinate transfer

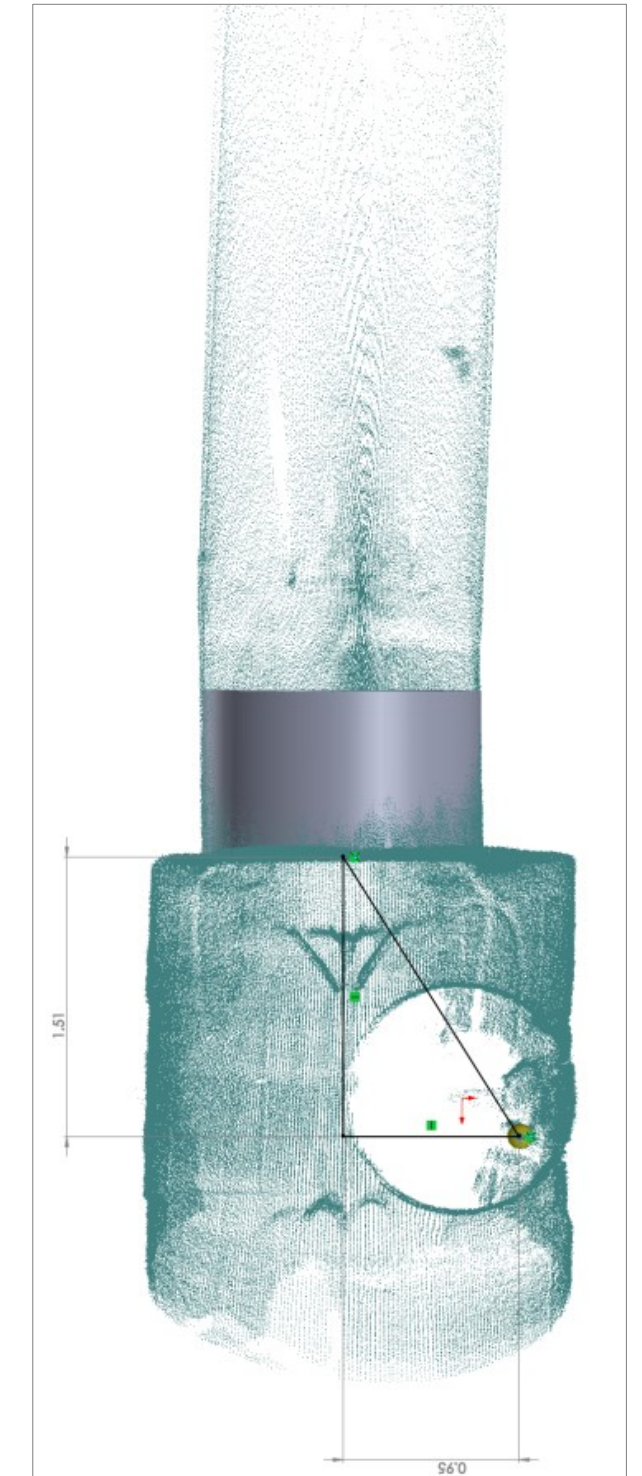
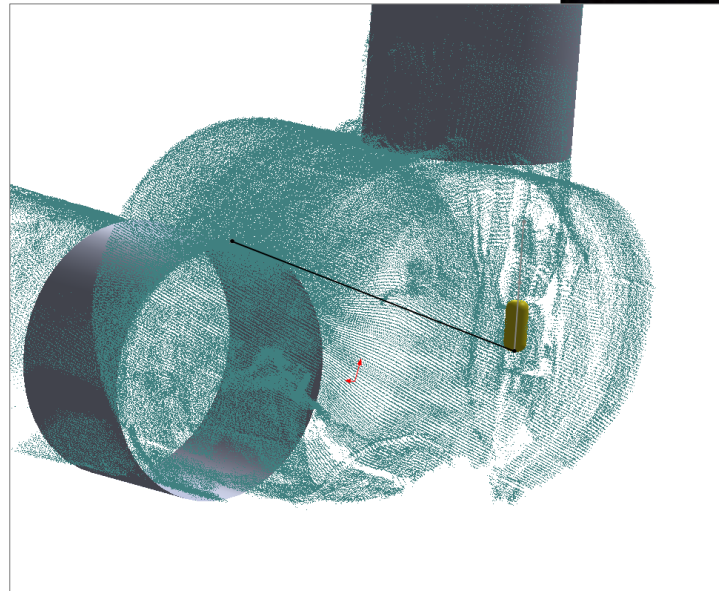

Edmonton Alberta, CA (cont.)

Drill and Rehab Project

N-S Bypass Pipe – Bend Analysis

- Import point clouds into CAD
- Define pipe wall and CL
- Measure angles
- Update 3D model

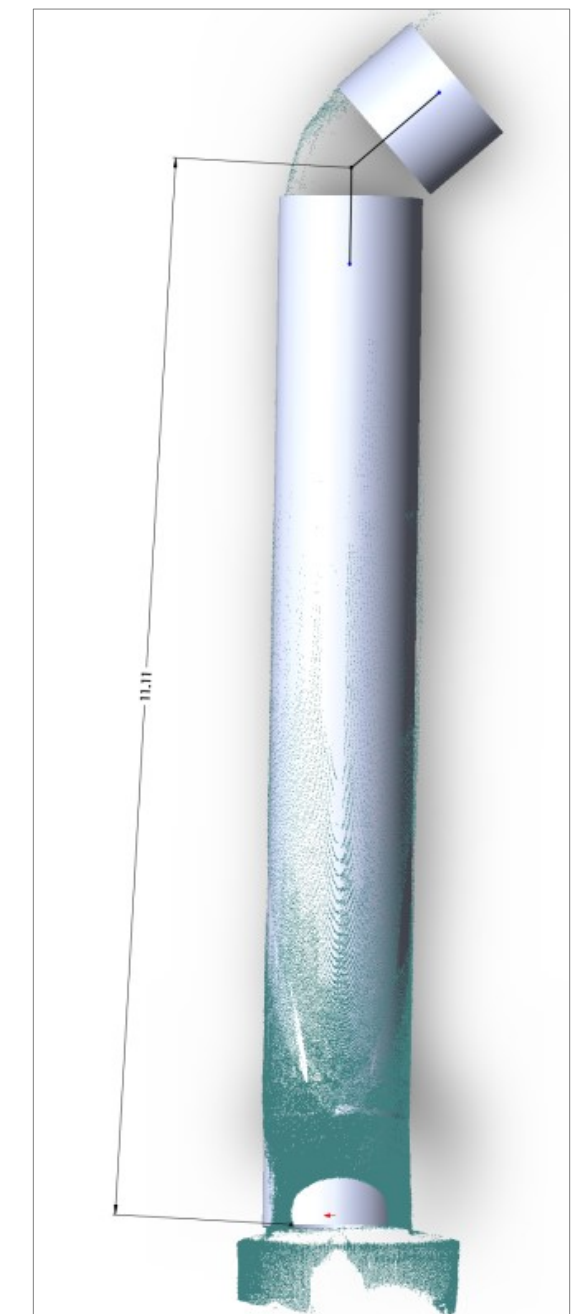
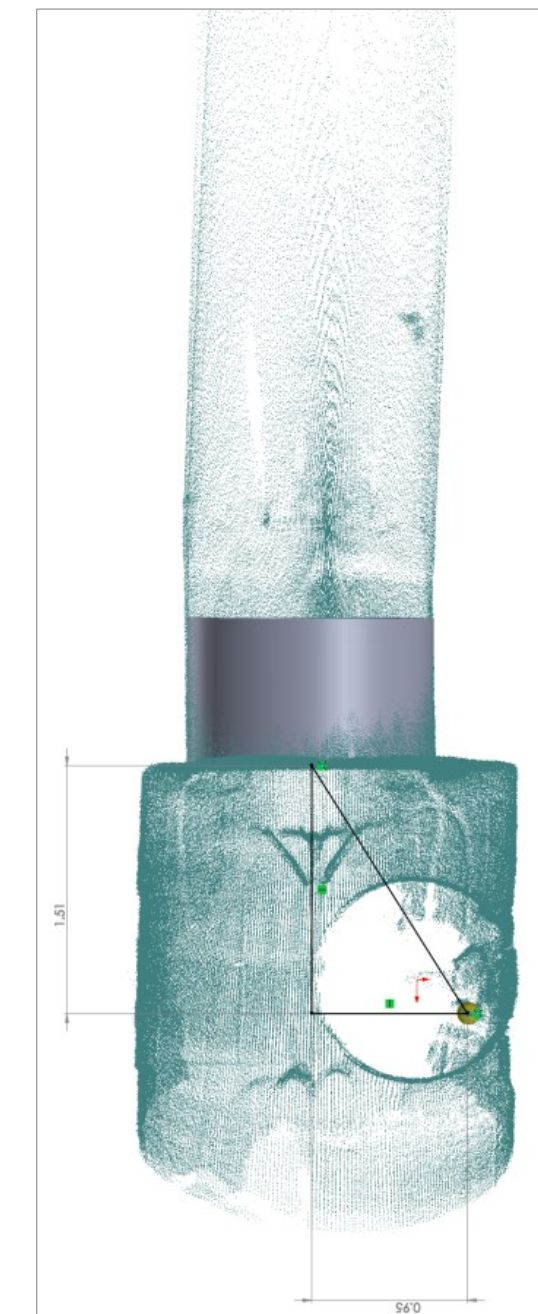
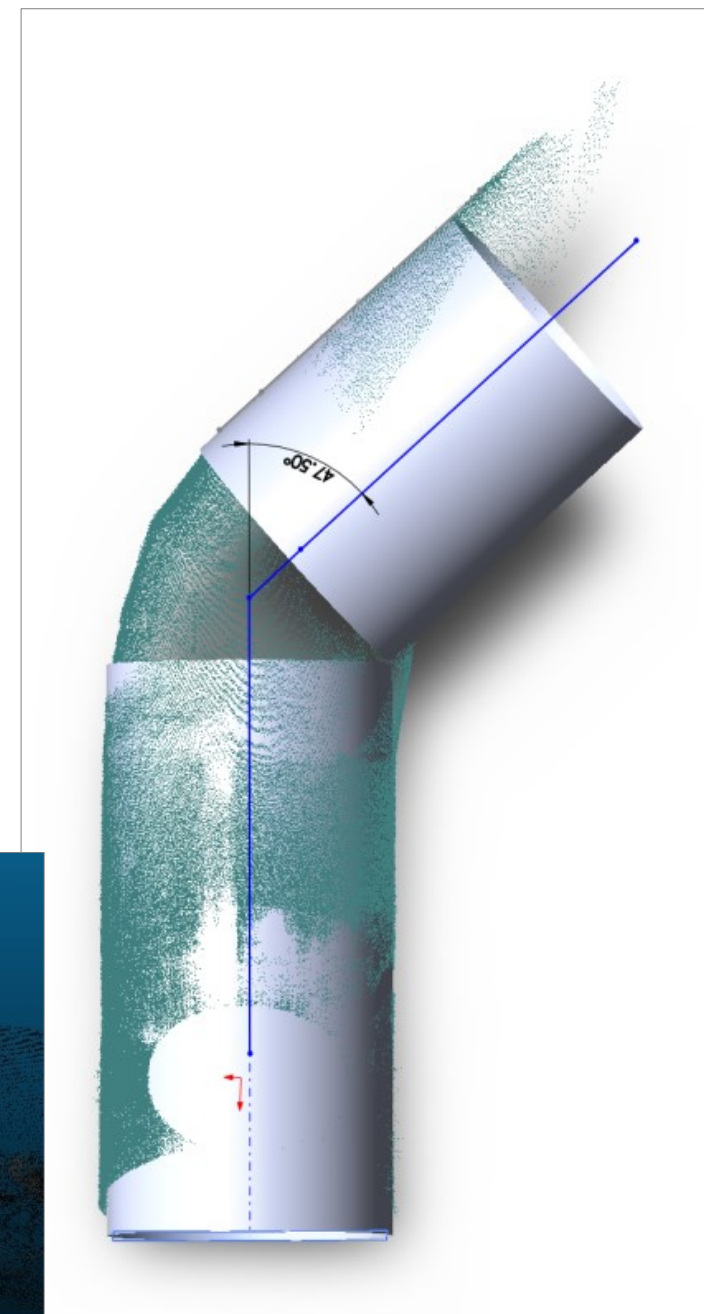
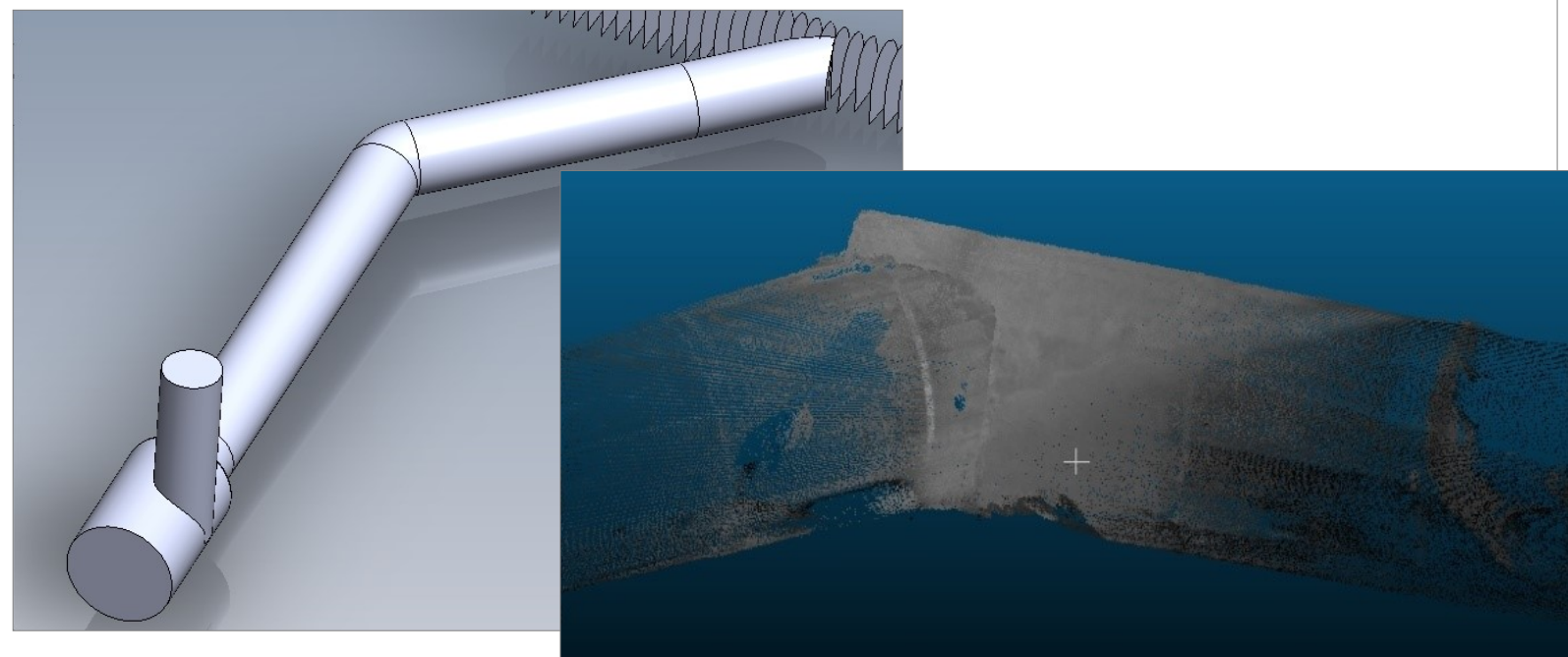

Edmonton Alberta, CA (cont.)

Drill and Rehab Project

Tie The Pipe And Tunnel Together

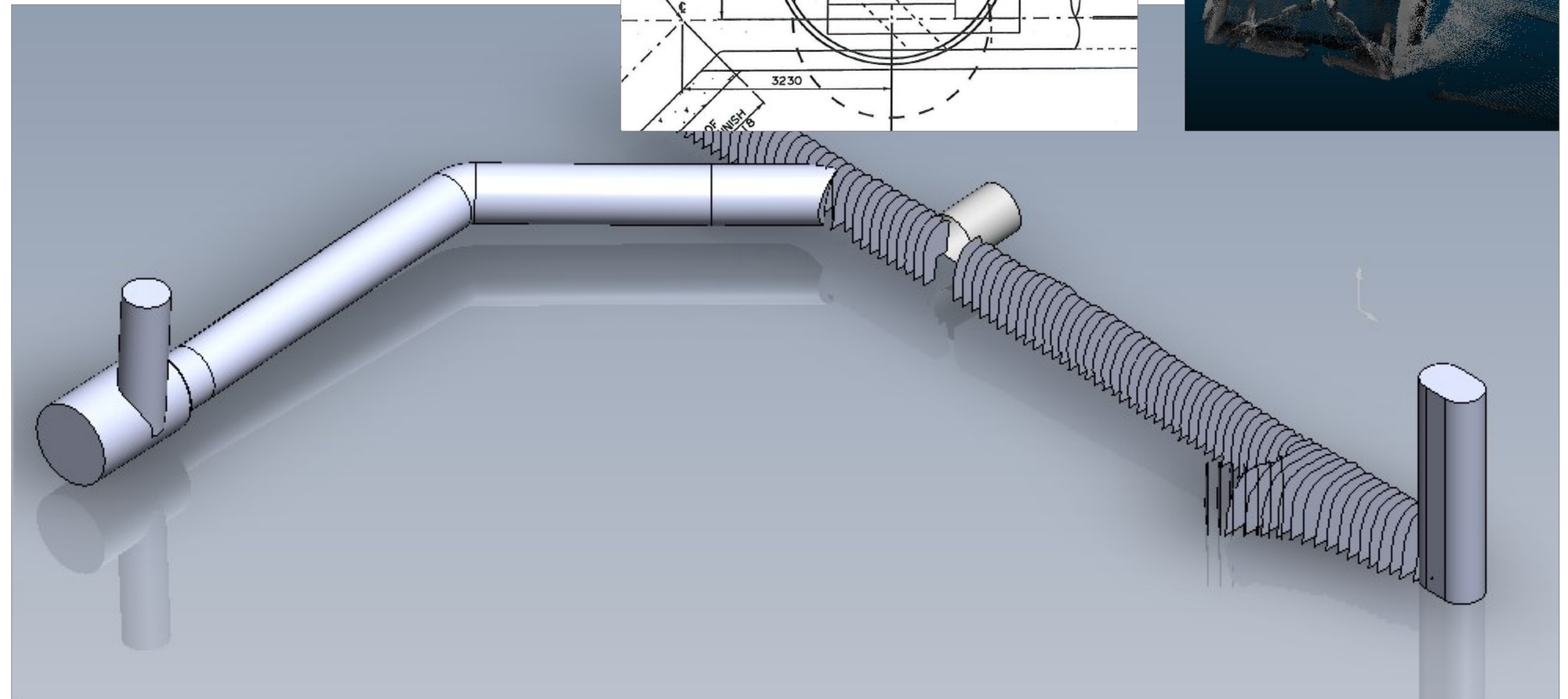
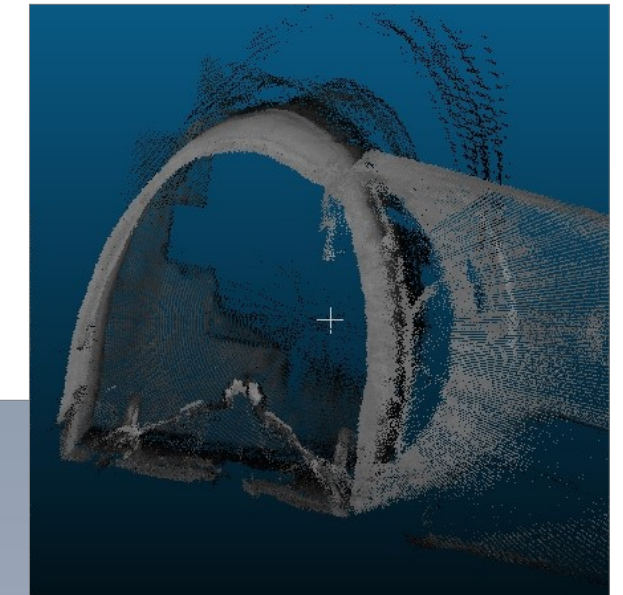
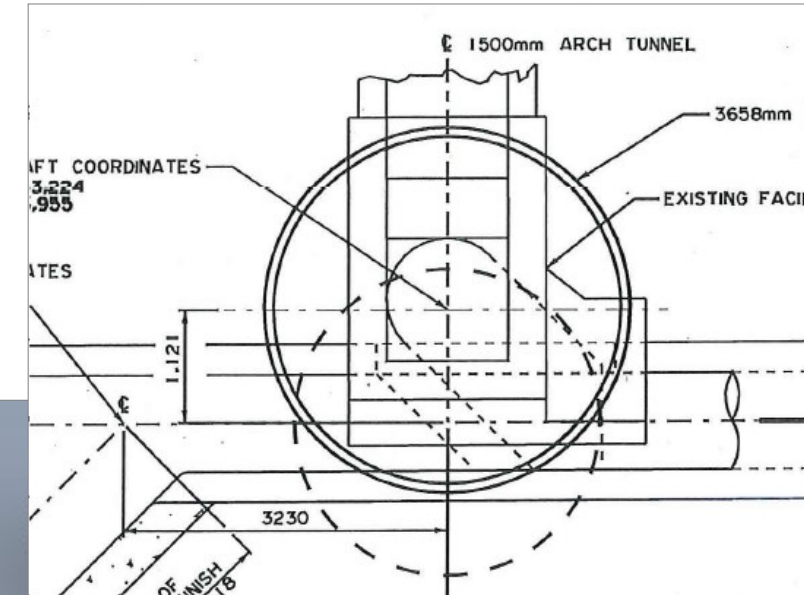
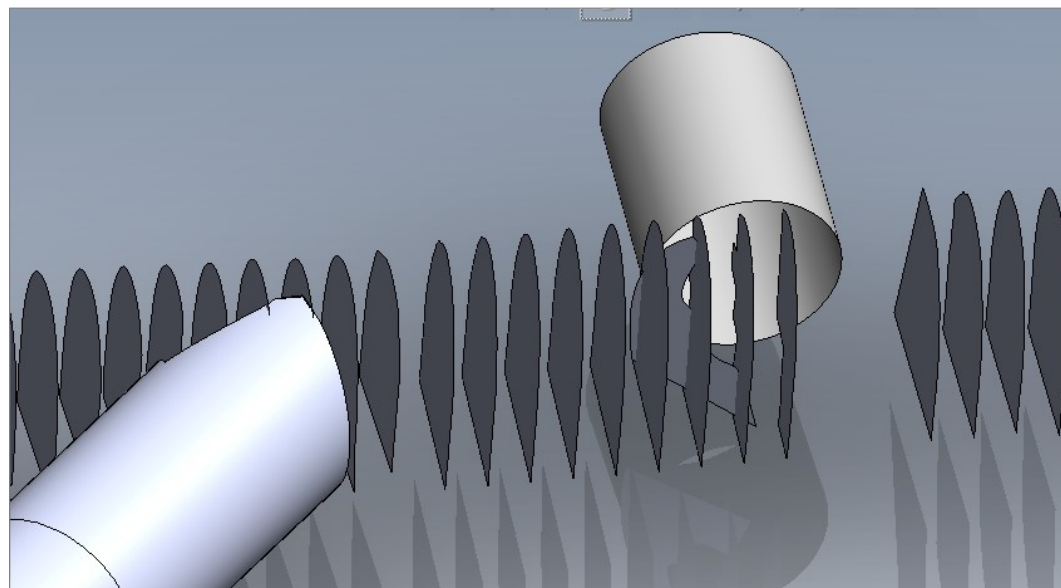

Edmonton Alberta, CA (cont.)

Drill and Rehab Project

Deliverable – Access Shaft Dig Coordinates

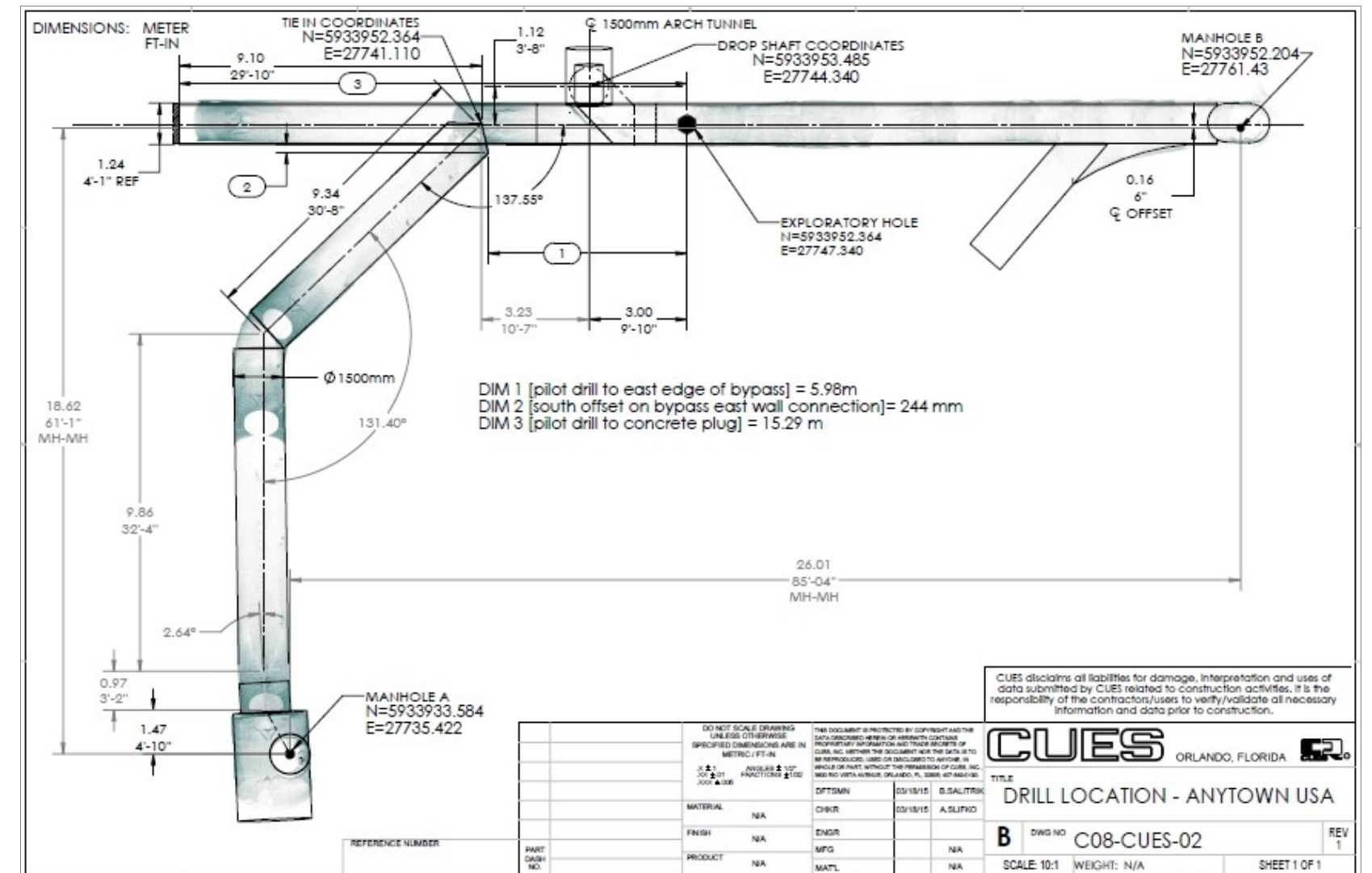
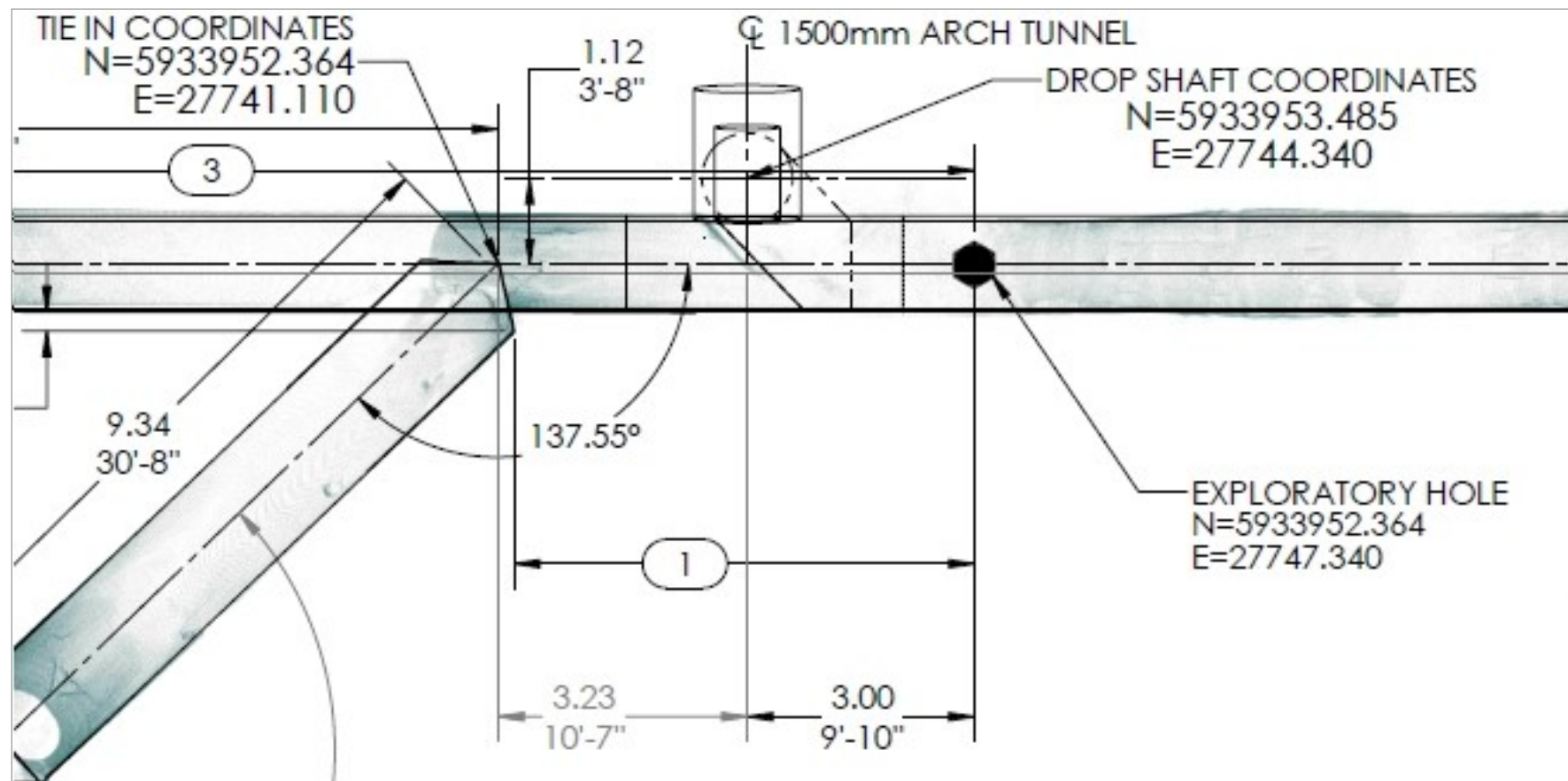

Edmonton Alberta, CA (cont.)

Drill and Rehab Project

Results – Exploratory Hole For Shaft

- String line to South wall – 500mm
- String line to North wall – 490 mm

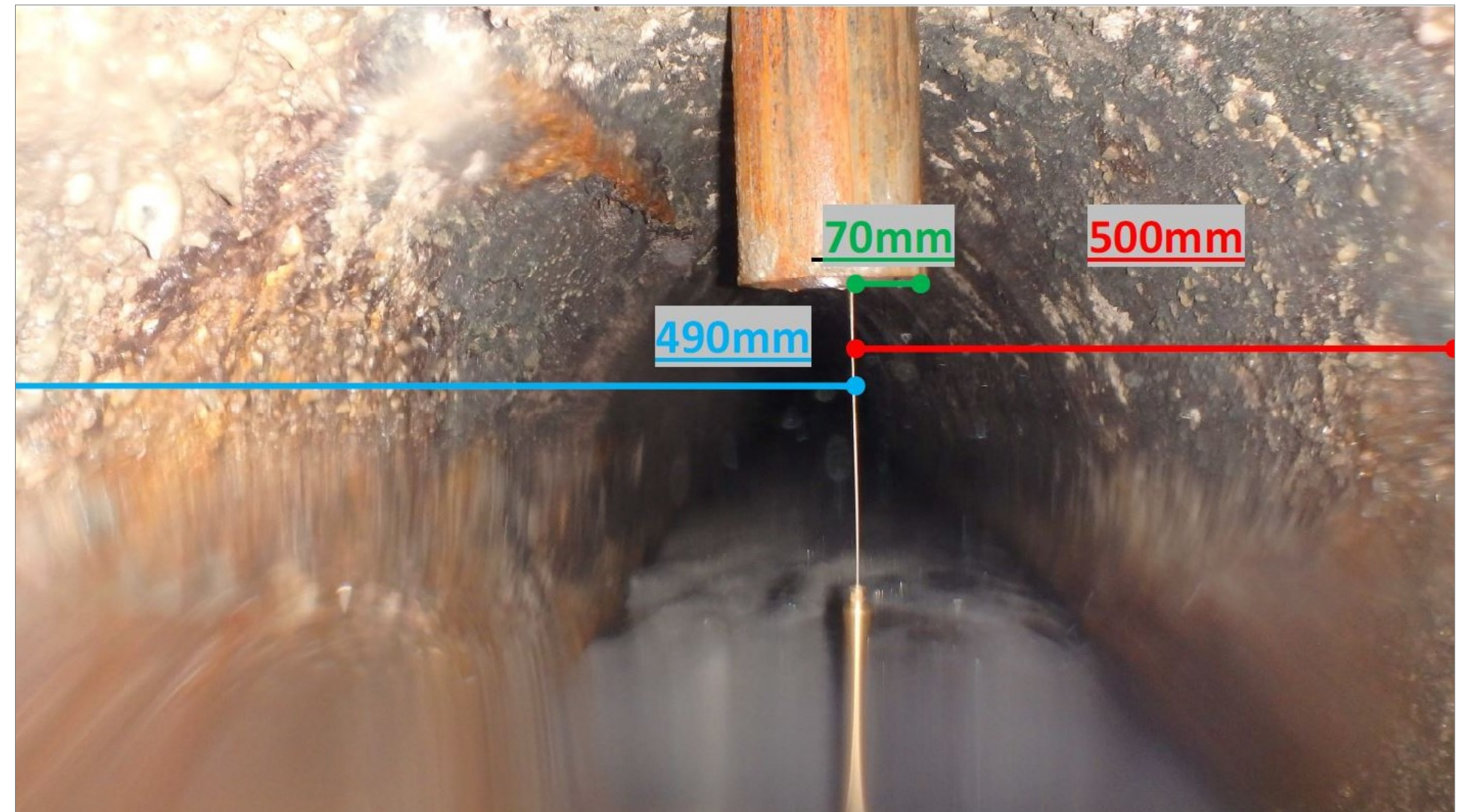

SFX-Advantages

Live view of video and data

- Code in field or office
- Verify data quality in field
- Reduce re-work

Blow-off system for clearing lens

- No need to pull back
- DUC lens & LIDAR lens

No Shadowing

Accuracy is constant as pipe diameter gets larger

Factory calibration

2D Inspection Technology Comparison			
Feature	SOLID FX -2D	Rauch	Fly Eye
<i>Technology</i>	LiDAR	Spinning Laser Profiling	Laser Profiling with Wand
<i>Cross Sections Scan Rate</i>	45 /second	1.25 /second	12 /second
<i>Cross Section Measurement Density</i>	1080 points	20 -300 points	Function of Pipe diameter
<i>Effective Range</i>	6"- 30 meters	4"-48"	18"-100"
<i>Accuracy</i>	3 mm @ 10m	15mm @ 3m	3 mm @ 3mm
<i>Resolution</i>	1mm (constant)	+/- 0.5% (pipe diameter)	+/-0.1% (pipe diameter)
<i>Calibration</i>	Precision Factory	Automatic	Factory
<i>Limited by Shadowing</i>	No	No	Yes
<i>Requires Wand Change out</i>	No	No	Yes
<i>"Cork Screw" Distortion during Motion</i>	No	Yes	No
<i>Multiple Returns (fog resistance)</i>	Yes	No	No
<i>Sensor Cleaning during Inspection</i>	Yes	No	No
<i>Transport Mechanism</i>	Tractor/Float	Tractor Only	Float Only
<i>3D Option</i>	Yes	No	No
<i>Custom Reporting</i>	Yes	No	No
<i>Live Video</i>	Yes	Yes	No
<i>Sonar Available</i>	Yes	No	Yes
<i>Maximum Deployment Length (m)</i>	2000+	2000	2000+
<i>Data viewable during operations</i>	Yes	Yes	No
<i>Onsite PACP/WRC</i>	Yes	Yes	No

Multi-Sensor Inspection: 2D LIDAR & 3D LIDAR

